

Building Bulletin 99 (2nd Edition):

Briefing Framework for Primary School Projects

Incorporating primary school revision to BB82: Area Guidelines for Schools

The key purpose of this document is to set out simple, realistic, non-statutory area guidelines for primary school buildings. The document supersedes Building Bulletin 82: Area Guidelines for Schools, published in 1996, and any associated revisions. Essentially the document gives minimum areas for all types of space in primary schools. It also offers area ranges over and above this minimum to allow schools flexibility in the design of their buildings and the way in which they use them.

Following comments on the draft Building Bulletin, published in 2003, and the publication of the 'Exemplar Designs for Schools', the recommended gross¹ area of primary school buildings has been increased to an average of 25% above the upper limit as set out in Building Bulletin 82 in 1996. Funding from the Department for Education and Skills (DfES) will enable new primary schools to be built to these standards.

You can use the simple graphs and formulae in Part C to ensure that the number, size and type of rooms in new designs, refurbishments and remodelled buildings are at least that recommended. These have been calculated to address not only the requirements of the curriculum, but also the needs of pupils with special educational needs (SEN) and disabilities, the school workforce and the community. Similar information is given for site areas.

Crucially, we also recommend a 'float'² to accommodate the individual priorities of each school. Every mainstream school is expected to need at least the total net area³ recommended, which includes the 'float'. Some schools may have further supplementary area⁴, usually funded from additional sources, over and above this, for instance for an increased sports hall. A graph showing the recommended non-net area⁵ and its relationship to the net area is also given.



1 What is the gross area? The total area of the buildings, not including the external walls, but made up of net and non-net area. Fig C.2, page 26 identifies these areas in diagrammatic form.

2 What is the float? When the recommended minimum area of each category of space is added together the total will be around 8% less than the recommended standard for the total net area. This difference provides the 'float' which can be used to enhance some areas, depending on the priorities of the school.

3 What is the net area? All spaces in the gross area of buildings except toilets, washrooms and showers (and lobbies to them, including changing rooms where these adjoin showers), plant areas such as boiler rooms, circulation space, school kitchens and the area taken up by internal walls.

4 What is supplementary area? Spaces which are not part of mainstream accommodation which enhance use by the community, disabled pupils or specialist teaching and are funded through separate means. Page 51 lists examples of such spaces.

5 What is the non-net area? All spaces listed as exceptions within note 3.

However, getting the area right is only part of creating facilities which support the educational aims and vision of each school. Design quality and appropriate specifications are also crucial. Part A supports the need for a strategic masterplan and a carefully considered brief to ensure that the design takes on board the organisation, aims and priorities of the school.

Creating a good brief is the first important step towards the success of any building project. Part B aims to highlight to local authorities (LAs) and all those involved in the early stages of a primary school project the general points that need to be considered. It summarises the key points, with references to further information in other guidance.

Appendices 1, 2 and 3 look in detail at schedules of accommodation and the kinds of room types and numbers which can result from a series of key decisions made by the client.



contents

	page
Part A: The ‘Masterplan’	9
1: Strategic scheme	10
2: Outline schemes	11
3: The reference scheme	12
Case study	14
Part B: Design Criteria	15
1: The school’s overall vision	15
2: Implications for the design	17
3: Key design requirements	21
Part C: The Buildings	25
Gross area of buildings	25
Net area of buildings	27
Schedule of accommodation	28
1: Basic teaching area	29
2: Halls and studios	39
3: Storage	40
4: Staff and administration	41
5: Learning resource areas	43
Non-net area of buildings	45
1: Toilets and personal care	45
2: Kitchen facilities	49
3: Circulation	50
4: Plant	50
5: Internal walls	50
Supplementary areas	50
Part D: The Site	53
Net site area	55
1: Sports pitches	57
2: Games courts	57
3: Soft play	58
4: Hard play	58
5: Habitat areas	58
Non-net area	59
Supplementary site area	59
Appendices	
Appendix 1: Example schedules for various sizes of infant and junior schools	61
Appendix 2: Example schedules for various sizes of 5 to 11 (JMI) schools	62
Appendix 2: Example schedules – various options for 420 place schools	63
Appendix 4: Key Formulae	64

Questions and Answers

1: What do flexibility and adaptability really mean?

Flexibility is the ability to change things in the short term, for instance sliding/folding partitions which can be moved to create two spaces or furniture which can perform a number of functions. Adaptability is about designing the building for possible long term changes and includes such features as the need to keep services to outside walls so internal walls can be moved at a later date and ensuring that buildings are a shape which allows them to be extended easily (see page 21).

2: My client wants to have the top of the range for all areas of the school. The budget will not cover the area which this requires – how do I ensure my client is happy?

It's all about your client's priorities. Extra space can be gained within the budget but this may be at the expense of specification in areas such as finishes, furniture, materials etc. Your client should be made aware of the choices necessary and their implications, including immediate and long term maintenance commitments.

3: My school is on a tight inner-city site – do I really need the range of outdoor spaces recommended in BB99?

No, the recommendations are just that. It is accepted that in inner city areas other arrangements have to be made such as using local leisure centres etc. Constrained sites, as defined in Part D, are generally recommended to have the zone below.

4: My school wants to deliver an integrated ICT curriculum, how should the building brief reflect this?

Integrated ICT activities usually occur in classbases, however they may also be carried out in group rooms or more informal areas such as libraries. If desktop computers are provided then the upper range of classroom areas should be used. If, however, wireless laptops are used then there are fewer accommodation issues. Internet access may also be wireless although if this is not available a bank of networked desktop computers could complement the provision of laptops. The description of shared teaching (see page 29) explains the choices in details.

5: Can I use my float to make my sports hall bigger?

Yes, provided that you are able to afford it within the capital allocation you have been given (which is usually based on all areas being within the middle of the recommended zones). If you provide the minimum for all the zones you should have around 8% of area left to put where you want. Appendix 3 variation 2 shows an example.

6: Do I calculate the area of the room from the internal face of the internal walls or from the centre as is the norm in most architectural schemes?

The internal face of walls, because this is traditionally the way the net area and net capacity are measured and we are keen that the two processes are as similar as possible. The area of internal walls is a significant part of the 'non-net' area.

7: We are proposing in our design to have discrete indents, some of which will form passing places for our wheelchair users and some of which will be for display and informal ICT use. Does this all have to form part of our circulation allocation?

No, see the net capacity definitions at www.teachernet.gov.uk/netcapacity. Corridors are counted as circulation (and, therefore, as part of non-net area) if they are under 2.5m wide. Any part of the corridor which exceeds this is counted as net area. In your case this area would be counted as general, resource workplaces.

8: What do you mean when you say fully inclusive?

In the context of classroom layouts 'fully inclusive' means that which enables a pupil using a wheelchair to access all areas of the room, and therefore all activities easily, without any disruption to classroom layouts.

9: What is the difference between extended school facilities and community use?

An extended school building could be used by more than the local community, it could be shared by a number of other organisations such as health or social services.

10: We will be taking three wheelchair users in our first year of opening – how should I accommodate them in the classroom?

To be fully inclusive you should be looking at the top end of the large classroom zone (zone D). This should ensure that the pupils can get around the classroom without disturbing the layout, which should help to make the activities fully accessible.

11: I can't rely on having enough teaching assistants to allow a timetabled separate practical space – yet I want at least half the class to carry out art and design activities at any one time, how can I achieve this?

You could use the middle school model of practical bays off classrooms and swap classes where needed.

12: Why can't the MI room be used as a sick bay as well?

It can be, and often is, however they do have separate functions. Medical inspections are regular but infrequent and are carried out by visiting specialists. A sick bay is for children who are feeling unwell and who are waiting for parents and carers to pick them up, for this reason it is best sited near the entrance.

13: My Year 6 pupils are embarrassed at changing for PE in the classroom – how can I ensure I get changing rooms in my new building?

You can use your float for changing rooms, Appendix 3 version 2 gives you an example of how this can be achieved. However this will mean going towards the bottom of the range in some areas. In some cases it may be appropriate to provide one changing room with the opposite gender changing in the hall.

14: We're a small school yet my staff would dearly love a music room – is there any way this could work?

Some schools have divided their hall into two sections with an acoustic screen between, so that the hall can be larger for assemblies and PE but divided up for lessons. Again the float could also be used to provide an extra specialist space.

15: What's the best way to organise pupils' bags and coats?

This depends on your school's ethos and how circulation is organised. If each classroom has a direct exit to the playground then storage is best as near to the rooms as possible. If there are few exits then a centralised coats and bags arrangement may be more useful.

16: My old building had the toilets in a centralised area – is this still appropriate?

Again this depends on your school's ethos. Your LA may be able to advise you on this. Security of pupils must, however, be the most important consideration.

17: Do I need a staff room which enables all staff to work and socialise together at any one time?

No, work and socialising can often take place in separate areas. A teacher's half a day a week of non-contact time (as part of the school workforce regulations) will require a specific area for them to work, outside of the classroom. There is a particular need for a separate space in larger schools with a number of teachers working at any one time.

18: As a Headteacher I want a single library in a central position, yet my staff are keen to have two smaller libraries for infants and juniors. I can see some logic in this, however which is the better option?

It is a decision for you as the school to make with the help of your LA. Consider the implications of your decision both in terms of resources and school re-organisation. Two separate spaces will allow specialisation of resources, but consider how you might staff them.

19: Why is there a higher ratio of computers to pupils shown in the schedules of smaller schools?

In the schedules we have allowed for two computers in each classroom. In the ICT space we have assumed either 15 (for half a class) or 30 (for a full class) computers. In a small school this policy results in a higher ratio of computers, however, it is felt that it is a workable solution for all schools regardless of size, at least for the present. Use of wireless technology and integrated ICT may make this model obsolete over time, this is discussed in Section C with the Basic Teaching pages.

Introduction

This document is designed to assist Local Authorities (LAs) and other stakeholders in the creation of a brief¹ for any major project in a mainstream primary school. The aim of this ongoing briefing process is to clarify the intentions of the client² and to inform the design team of the requirements for the project.

Particular emphasis is given to the following issues:

- Part A: the **process** of creating a brief, and how it should fit within a strategic masterplan³ incorporating the school's long-term vision;
- Part B: the key **design criteria** that should be included to ensure the facilities are appropriate and usable for present and future circumstances;
- Part C: minimum **building** area recommendations for each of the five categories of space within the usable or net area, and for the remaining area of the buildings;
- Part D: minimum **site** area recommendations for the various categories of outdoor spaces needed within the net site area.

Side notes on each page give references to further information and guidance, including exemplar designs.⁴

Context

It is important that the brief for any building project is seen in the context of the overall strategic 'masterplan', to avoid work being done in the wrong place or in the wrong order. It is equally important that the 'masterplan' is in line with the aims of the LA's Children and Young People's Plan, operational asset management plan and other strategies, for instance accessibility⁵, community and sport.



© Dennis Gilbert/View

1. What is a brief? The NBS (National Building Specification) Educator states that 'briefing is the process of identifying a client's need and finding an appropriate solution. A brief is a product of that process and is produced at key points in the project and formalises decisions and instructions in a structured document. The briefing process is iterative and moves from the general to the particular.' See www.nbseducator.co.uk/briefs/homebriefs.shtml

2. Who is the client? The LA or other responsible body is the main client but the client body includes school staff and governors, pupils and parents; all of whom should be fully involved in the briefing process.

3. What is the masterplan? A series of linked processes that ensure the final scheme reflects the LA's overall planning strategy, the school's educational vision and the designer's creativity.

4. Exemplar designs have been developed by some leading architectural practices working to a DfES brief, to improve the design quality of school buildings. The designs, including five primary schools, are intended to develop a shared vision of 'Schools for the Future' and create benchmarks for well-designed schools. For further information see www.teachernet.gov.uk/exemplars

5. The Disability Discrimination Act 1995, as amended by the Special Educational Needs and Disability Act 2001, introduced Part IV 'Education', which required LAs to have an Accessibility Strategy for schools to increase access to information, the curriculum and the physical environment for disabled pupils, over a three year period to March 2006. See www.teachernet.gov.uk/wholeschool/sen/schools/accessibility

Figure A.1: chart showing the key processes of the briefing process and how it relates to the RIBA's stages of work*

	brief	design	budget	Who's involved
1: Strategic scheme	All work required to address deficiencies of AMP and wider LA strategies	RIBA stage A: inception	Initial estimate of cost of each item of work, totalled	<ul style="list-style-type: none"> - LA - AMP surveyor
2: Outline schemes	Best feasible option to address issues above within a suitable overall plan that suits SDP	RIBA stage B: feasibility	Firmer cost estimate of all options, identifying the whole-life implications	<ul style="list-style-type: none"> - LA - School - Architect (CDA)** - Other stakeholders
3: Reference scheme	Schedule of accommodation and key links	RIBA stage C: outline design, architects plans	Robust cost estimates based on the proposed design	<ul style="list-style-type: none"> - School - Architect (CDA)
4: Final scheme	Detailed output specification based on 'Masterplan'	RIBA stage D: scheme design (may be all or part of masterplan)	Capital and whole-life costs of project	<ul style="list-style-type: none"> - School - Architect (CDA) - Engineers - QS

* www.architecture.com/go/architecture/using/contracts looks at fees associated with stages of work.

** A Client Design Adviser, who will advise the school on its brief and independently assess subsequent solutions. (See page 11).

Part A: The ‘Masterplan’

Any school can benefit from a ‘masterplan’¹ for the building work required. This will initially be a list of work necessary to address any deficiencies that have been identified in the Asset Management Plan (AMP). This list can be developed to become a premises development plan, covering all the building work needed on the site, based on a detailed design brief.

At each point in the ‘masterplan’ process the following issues will be identified, in increasing levels of detail:

- the brief, specifying what is required;
- the design, starting with a ‘first stab’ at what is needed, leading to a feasible masterplan for the whole site;
- the budget, likely costs and possible sources of funding²;
- the overall timescale involved, including any phasing or priorities for particular projects.

Figure A.1 opposite summarises the likely work involved at each stage, and who might be involved.

The brief for any project will need to be written by the client team (as described on page 13). It can then be developed further by the wider design team as building professionals become involved³.



© Paul Middleton

1. BB98 ‘Briefing Framework for Secondary School Projects’ and ‘Schools for the future: Transforming Schools’ look in more detail at the process of formulating a masterplan.



2. For up to the minute information on school funding go to www.teachernet.gov.uk/management/schoolfunding
3. A useful introduction to the roles of those involved in building projects is ‘A Guide for School Governors: Developing School Buildings’, published by RIBA. Available, quoting ref:WS/GFG, from RIBA policy, 66 Portland Place, London W1N 4AD priced £6.50

1: Strategic Scheme

A key responsibility of any LA is to ensure that there are sufficient pupil places in the most appropriate locations. They must be aware of demographic changes within their authority and be prepared for increases and decreases in the pupil population. Local Authorities are also required to identify an authority-wide strategy for community provision in schools, as well as specialist provision for pupils with SEN or disabilities. Recently LAs have been required to draw up an accessibility plan to ensure that all mainstream schools are able to accept disabled people.

Over the last few years, asset management plan (AMP) surveys have required LAs to assess school buildings and grounds in terms of their condition (whether they are in a good state), suitability (whether they are appropriate for their use) and sufficiency (whether there are enough pupil places and overall area for those places).

Gathering and analysing the resulting data of all these assessments has enabled LAs to identify which school buildings across their authority are most in need of rebuilding, major remodelling or minor refurbishment and prioritise accordingly. At each school, the overall work required can form the template for all subsequent work, upon which other decisions can be made later.

This **strategic planning** will be based on the work needed to address any deficiencies identified in the AMP, and on the Local Authority's broader strategies such as inclusion, pupil place planning and extended schools. Questions to be considered include:

- do existing facilities need to be adapted or refurbished to address any suitability or access needs?
- do any buildings need to be demolished, as they are surplus or beyond economic repair?
- does the building need to be expanded to take on an increased local population or for other community needs?
- does the building require more land or does it have a surplus, the sale of which could be used to fund building work?



© Paul Middleton

2: Outline Schemes

Within the broad budget identified during the initial strategic planning exercise, a further feasibility exercise can be done by an architect or building professional such as a Client Design Advisor¹ representing the school, but working for the Local Authority. This allows other more detailed options to be considered that address the issues identified in the strategic scheme but also match other issues that may be important to the school, such as moving the entrance to be more welcoming or reorganising the buildings to allow every space to be accessed without going outside.

This second phase will therefore incorporate both the Local Authority's and the school's education and community objectives, as set out in its School Development Plan (SDP). These two objectives will essentially form the brief.

The true feasibility of the proposals should be tested through desktop studies of the site and further surveys if needed, for example to ensure that the position of a new block does not cause prohibitive expense because it would span a main drain.

At this stage, a schedule of accommodation should be identified for the general brief. This may draw on the Local Authority's 'standard' model for the age range and size of school, which is in turn based on the typical schedules in Appendix 2. In some circumstances other agencies may also wish to be involved in the project, for example it may be possible to incorporate a Sure Start Children's Centre. This could bring additional funds and possible economies of scale. The other agencies' requirements must also be included in the brief.

Local Authority building officers and educational advisors will be able to help the school to appraise the options that the building professionals have drawn up, and to confirm that the proposals are in line with the school's SDP. The team will also need to compare the capital costs to whole-life costs of the various options, as the recurrent costs of heating, cleaning and maintenance can be significant for the school (even if indirectly, in a Public Finance Initiative (PFI) or similar project) long after the building work is complete.



1. The Commission for Architecture and the Built Environment (CABE) and Offices for Government Commerce (OGC) both recommend that publicly funded projects should use Client Design Advisers: experienced architects who are expert in the sector and can advise on the best brief and feasibility scheme. The RIBA Client Service can provide names of RIBA accredited architects with appropriate educational experience at 020 7307 3700 or cs@inst.riba.org

3: The Reference Scheme

When the option has been identified which best meets the needs of all parties, a detailed brief¹ for the whole school can be developed.

At this stage, therefore, the LA's schedule of accommodation may need to be amended to match the precise requirements of the school's curriculum and organisation. It should also set out the key principles that the design team will need to understand, also covered to some extent in Part B, and an outline of the school's SDP that includes the organisation, ethos and aspirations of the school and their implications for any building projects.

As the LA were required to do, the school's SDP should incorporate the needs of pupils with SEN and disabilities and of the community, and the increasing needs of the school workforce. In addition, matters that should also be considered include:

- the planned curriculum and the activities needed to teach it, for example if art or design and technology is to be taught as a timetabled subject will the school require a specific room;
- whether the school teach ICT as a discrete subject to a full or half class, and if this is to be with desktop equipment, which will require a separate space, rather than laptops;
- whether the approach to furniture and equipment (F & E) is to be as flexible as possible;
- whether bags and coats are to be stored in the classroom, the corridor or in a separate area;
- whether there is access to the playground directly from the classrooms;
- whether staff prefer to socialise and work in the same space.



© Marc Davis/CFG



¹. Part B gives more information on the key aspects of writing the brief

4: The Final Scheme

The detailed brief will ensure that the designers involved understand the context as well as the specific requirements of the work. The designers will then be given the opportunity to propose a number of detailed design options incorporating the objectives set out in the SDP. The options will identify issues such as room relationships, generic F & E layouts, numbers and types of rooms and the position of shared areas such as the hall and the library. These options can then be costed and compared to each other and to the original scope of works. A decision may then be made on the most appropriate solution.

Depending on the size of the project, it may be realised through a single build or a series of phased small projects, all of which will then have their own more detailed project brief – this will be the final part of the masterplan process.

Phasing should be carefully scheduled to avoid early projects adversely affecting later ones. Figures A.2 and A.3 on the next page show a case-study example of a phased approach.

The Client Team

By this time a client team will have been created to make these decisions. The team, depending on the size and type of project, usually includes:

- those responsible for providing pupil places and the school estate, usually the Local Authority and/or diocese;
- the fund holder(s), e.g. governors, bursar, Local Authority building officers etc., who need to be sure that the brief is achievable within the budget and allows for future changes (for instance in staff and organisation) and community use;
- building professionals, e.g. architects, who may then go on to building stage;
- senior school staff and governors, who will need to ensure the design is suitable for the individual needs of the school;
- other stakeholders, for example local community groups who may wish to use the facilities, or those interested in providing further funding for multi-agency provision on the school site, such as childcare or social services; and
- the main users of the project, i.e. the staff and pupils.



1. School Works produces material to help set up participatory design projects in schools. Useful publications include 'Learning Buildings' and the 'Toolkit'. See www.school-works.org.

Figure A.2: Case Study: Plan showing phasing of new and refurbished school buildings

The case study featured below is a 293 place inner city Primary school. The school had a number of pupils in wheelchairs and, as such, was keen to link all three of its existing buildings to allow these pupils full access to all parts of the curriculum. In response to this brief, the architects developed a 'masterplan' for the buildings which incorporated the need for inclusion as well as a new ICT/resource centre for the community, new entrance to the school, and a covered play area for the infants. The challenges of joining two 1970s buildings with a Victorian building in a conservation area, along with meeting the various needs of pupils and the community, required a sensitive solution. The architects worked closely with the school and the LA, in particular to reflect their vision and commitment to inclusive education. Separate funding streams meant the work needed to be carried out in three phases over four years.

Plan of existing school buildings

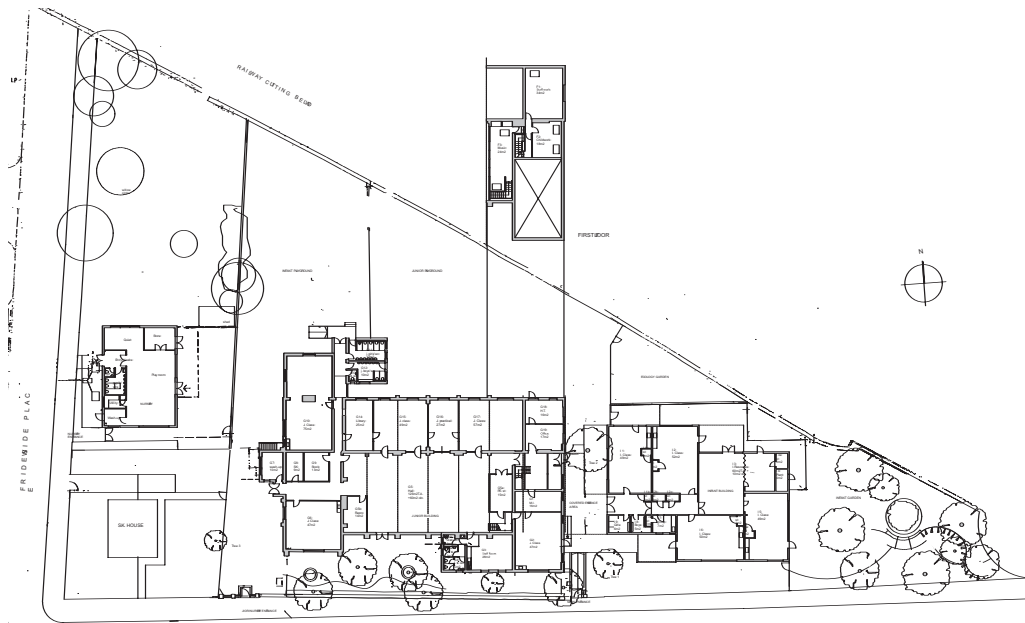

Phase A

- Hygiene facilities were provided in all three buildings and, as a result, children were able to be admitted into the nursery.
- Accessible group room created in the Victorian building.

Phase B

- New extension to house a therapy suite and MI room, movable partitions allow occasional joint use – resource now shared across LA.
- Circulation to the Victorian building re-planned.
- Enlargement of a junior classroom to accommodate a wheelchair station and computer.

Phase C

- New infill building, providing a new ramped entrance, library and ICT suite, and two SENCO rooms.
- Enlargement of a junior classroom.
- Fully accessible mezzanine created in Victorian block to provide offices and a group room.
- Refurbishment of garden and ramped external pergola leading to new infant covered play area.

Figure A.3: Case Study:

Plan of new and refurbished school buildings



Part B: Design Criteria

The project brief may evolve over time, with revisions made if the client's requirements change. However, at all stages of development the brief should incorporate key aspects to ensure that design quality¹ is achieved. These are:

1: The school's overall vision of how it will operate, deliver the curriculum, approach change and ensure excellence²;

2: The implications of the management of the school, for example the organisation of resources or the school's preferences for furniture and equipment; and

3: Key design requirements, for example the way in which flexibility and adaptability allow for change; the provision for SEN and disabilities; safety and security and environmental issues.

All these considerations will have an influence on the design. The approach should be determined through discussions with key stakeholders such as staff, pupils and parents. It may be useful for the design team to sit in on lessons and other key activities (if appropriate) to gain a fuller understanding of how the school works.

1: The school's overall vision

Any project within a strategic masterplan should ensure that the proposed environment will suit the identity, ethos and culture of the school. Along with other overarching aspirations, the brief should communicate to the design team that the buildings should inspire and enhance:

- **educational performance**, by providing opportunities to raise standards for all by offering an appropriate, adaptable and stimulating learning environment;
- **staff satisfaction**, through appropriate space for all staff to work, rest and socialise – vital for the recruitment and retention of the school's most important resource³;
- **pupil satisfaction**, for example, buildings that support good behaviour and self-esteem and, ultimately, the willingness and ability to learn;
- **community involvement**, which is an important way to make the school part of the community and maximise the use of facilities.

1. The Commission for Architecture and the Built Environment (CABE), in its publication 'Better Public Buildings', has identified good design as a mix of the following attributes: Functionality in use; Build quality; Efficiency and sustainability; Designing in context and Aesthetic quality.



2. The Construction Industry Council (CIC) has also developed design quality indicators to help to ensure quality in design. See www.cic.org.uk/ and www.dqi.org.uk/. A school specific Design Quality Indicator has been developed by the DfES and the CIC.



3. This is linked to School Workforce Remodelling, which is discussed at www.teachernet.gov.uk/wholeschool/remodelling. See also 'Removing Barriers to Achievement: The Government Strategy for SEN 2004'. www.teachernet.gov.uk/sen

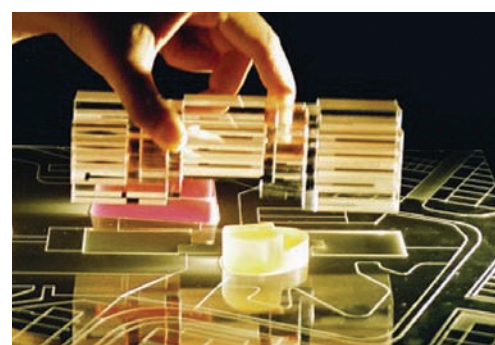
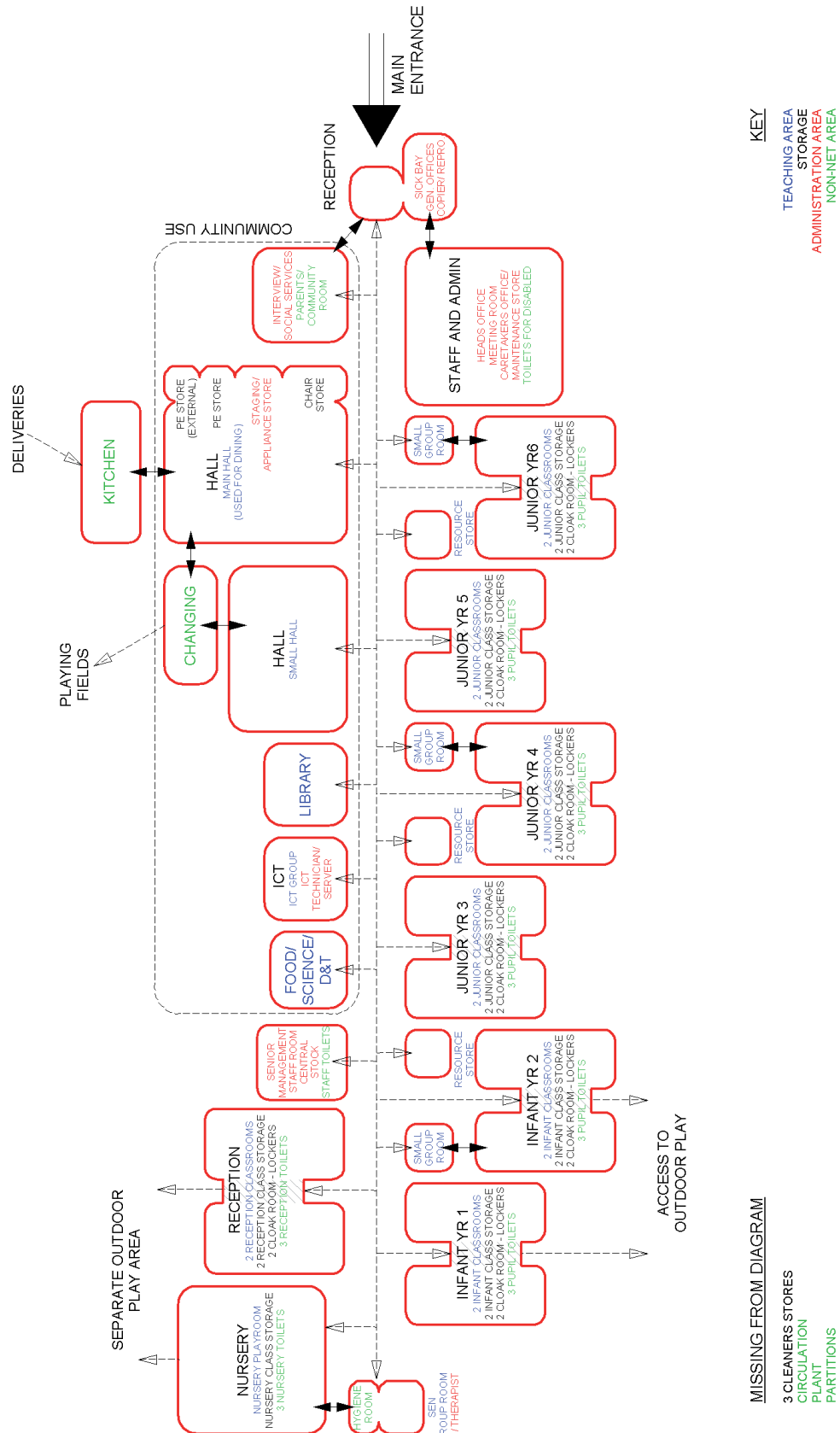

Figure B.1: Organisation Diagram

Diagram showing traditional year-based structure of a typical two-form entry (2FE) 5 to 11 primary school, and the useful links between areas. Various options are common which merge two or three adjacent year groups.



PRIMARY EXEMPLAR CORE BRIEF DIAGRAM

2: Implications for the design

At a more practical level, a number of key decisions about the organisation, management and pastoral support systems of the school can have major implications for the layout of the buildings. This is particularly the case when there are constraints on the site or where existing buildings are suitable but not ideally orientated, for example, too near a busy road or too far from vehicle access for deliveries.

School organisation

The school may prefer a year-based structure (as shown in Figure B.1 on page 16) or other groupings, such as mixed classes or key-stage clusters¹. Some large 5 to 11 primary schools prefer a separate infant and junior school structure. Similarly, some suggest that nurseries should be separate, while others have successfully mixed them with reception pupils to form a foundation stage unit resulting in successful sharing of resources and learning experiences.

The options schools may choose can involve significantly different building layouts, so it is important to determine these early on in the process whilst considering long-term flexibility.

Central or local resources

School resources such as books and paper may be deliberately centralised, with the advantages of easy access for support staff and more efficient stock management. Alternatively, particularly in larger schools, they may be spread around, for example creating curriculum-based storerooms which enable quick and easy access by teachers and pupils. These stores would be in addition to the ones associated with each classroom. Some small schools, however, may prefer larger classroom stores to incorporate resources for the specific subject each teacher has a responsibility for. This does however make organisation more difficult and may cause disruption if others need to access resources during lessons.

The choice: The brief should specify the location policy under each category of space, as discussed in Part C, covering ICT, learning resources, staff accommodation, personal storage and dining facilities.



1. Variations 5 to 7 of the primary school exemplar design brief give examples of these organisational options. See www.teachernet.gov.uk/exemplars

Furniture and equipment

Careful consideration of the activities required in each room should identify the items of F & E needed. This can then inform a number of layouts within the proposed rooms using notional sizes of F & E¹. The layouts will then go on to prove that the size and shape of the rooms are appropriate.

The furniture layout of any classroom should assist supervision and allow for:

- space to enter the room and good circulation around the room and between furniture, bearing in mind the active nature of many primary school tasks, the presence of teaching assistants or other adults and the need to accommodate pupils with disabilities;
- a teacher's workstation (not necessarily a desk);
- good sightlines for a range of activities, especially between teacher, pupils and any whiteboard or similar;
- a number of different furniture arrangements, with mobile items where possible to enable quick classroom set-ups;
- display surfaces (horizontal and vertical) for pupils' work, natural objects and both small and large artefacts;
- storage of resources arranged for ease of pupil access. Teachers may want some storage for their own use in the classroom, this could be provided at a higher level than pupils' storage;
- usually at least two desktop computers², portable laptops or tablets. Portable ICT frees up furniture for other activities, which can save space;
- easy access to coats and bags, if the school's policy is to store them in the classroom.

As F & E is chosen, layouts can be firmed up. Items significantly bigger than those shown in initial layouts should be identified and located. When specifying F & E, strength and stability should be assured by using relevant standards³. Ergonomics are also an important consideration and care must be taken to ensure that the items of furniture provided are of compatible height and suitable for pupils using it⁴. This is particularly true of work-surfaces and seating. The classroom diagrams on page 35 show a variety of layout options.



1. See www.teachernet.gov.uk/schoolfurniture for details of generic furniture sizes.

2. Best placed side by side, as this enables a teacher or teaching assistant to teach up to four pupils a particular skill at the same time (assuming two pupils working at each computer).

3. Both ergonomics and strength and stability standards for furniture are referred to in 'Furniture and Equipment: A Purchasing Guide', Managing School Facilities Guide 7, TSO 2000 (ISBN 0-11-271092-1) or may be downloaded at www.teachernet.gov.uk/schoolfurniture

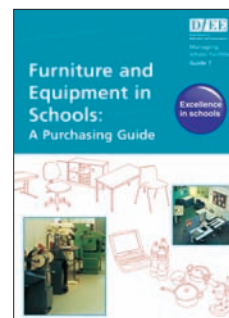

4. See the ergonomic furniture website at www.cfg.gov.uk/schoolfurniture

Approach to ICT¹

Portable ICT and interactive whiteboards can allow ICT to be taught to a full class group in the classroom, reducing pupil movement and the need for a separate ICT suite. However this does restrict opportunities for internet use as it is, at present, difficult to offer network outlets to 30 portable machines. Wireless networking access is an option, but has many implications for the building design and is therefore a decision which must be made early on in the design process. Wireless technology allows schools much more flexibility in how they use their buildings, for instance how they deliver ICT skills, where they position their computers and whether they provide ICT facilities in less formal areas such as the dining room. Many schools are, however, reluctant to use wireless technology at the present time because of management and usability issues. Some schools may feel it sensible, however, to incorporate wireless capabilities at build stage to allow long-term flexibility.

Extended school facilities

As part of their 'core' offer, most mainstream primary schools offer some of their facilities to children, their families and the wider community outside the school day. The level, frequency and likely timing of this community use should be assessed early in the briefing process as there may be significant implications for the design. This assessment should be done in conjunction with the authority-wide strategy for childcare, sports and leisure and may include other organisations such as health or social services.

The facilities most often used by the community are likely to include the main hall and its ancillary facilities, as well as the studio (if there is one) and any outdoor sports facilities. The design should allow these parts of the school to be open and heated while others are not in use.

Core facilities that will facilitate community use outside the school day, and that are allowed for within the recommended overall area¹, include:

- the option for the main hall to be a 180m² one-court badminton hall suitable for public use²;
- a parents/community room for one to one meetings, interviews and discussions as well as therapy sessions with children and parents;
- reception facilities and access suitable for out-of-hours use;
- community storage space separate from storage spaces used by the school;
- accessible toilets for use by adult visitors, including those with disabilities;



Hint: Use by community can affect VAT charged for building projects in Voluntary Aided schools.



Hint: Shared use can affect the requirements for emergency lighting and fire-escape provision to suit public use, and increase the demand for car parking.

1. The British Educational Communications Technology Agency (BECTA) has some useful information on issues of ICT installation at www.ictadvice.org.uk

2. For further information on extended schools, see www.teachernet.gov.uk/wholeschool/extendedschools

- external environmental learning areas³ that could be managed in partnership with specialist groups and the local community;
- the option of an all-weather sports pitch;
- a changing room, without shower.

If a school wishes to provide additional facilities (eg sport-related activities or parental support) over and above that allowed for in the recommended gross area then additional funding must be sought. This may be through a number of sources, see page 51.

In some schools, ‘extended school’ facilities² may be available for non-school use during the school day and, as such may need a greater resource provision than those provided for the community out of school hours. These facilities will generally fall into one of three types:

- facilities that are occasionally accessed by the wider local community during the school day – these should be available in any school, addressed through the design and management of the building;
- flexible multi-use areas for use by others during the school day. These will include a parent/community room or SEN facilities that are also used for community health care. These may be accommodated within the ‘float’ area or by some ‘supplementary area’ funded by the LA or another organisation;
- major areas of accommodation dedicated to non-school services. These would require supplementary area, funded by joining up with other funding streams, such as the Sure Start General Grant.

The location of any facilities that will be used by the community should be carefully considered, taking into account access, security, child protection, services and parking. Extended school facilities and supplementary area are discussed in more detail on page 51.

Shared use

As part of their ‘core’ offer most mainstream primary schools should offer some of their facilities to the local community outside of the school day. The level, frequency and likely timing of community use should be assessed early in the brief as there may be significant implications for the design. This assessment should be done in conjunction with the authority-wide strategy for sports and leisure amenities and may include other organisations such as health or social services.



1. These additional areas require use of some float and will ultimately require compromises in other areas of the school, eg: classrooms.

2. Refer to Sports England Technical Guidance Notes and ‘Designing Space for Sports and Arts’. See www.sportengland.org/resources/resource_downloads.shtml



3. What is an external environmental area? A facility which enables children to learn about the local habitat and to observe wildlife in their natural environments. (See page 58).

The facilities most often used by the community are likely to include the main hall and its ancillary facilities, as well as

the studio (if there is one) and any outdoor sports facilities. The design should allow these parts of the school to be open and heated while others are not in use.

‘Core’ facilities that will encourage community use outside the school day, and are allowed for within the recommended area¹, include:

- the option for the main hall to be a 180m² one-court badminton hall suitable for public use²;
- a parents/community room for one to one meetings, interviews and discussions as well as therapy sessions with children and parents;
- reception facilities and access suitable for out-of-hours use;
- community storage space separate from storage spaces used by the school;
- accessible toilets for use by adult visitors, including those with disabilities;
- external environmental learning areas³ that could be managed in partnership with specialist groups and the local community;
- the option of an all-weather sports pitch;
- a changing room, without shower.

If a school wishes to provide additional facilities (eg: sports related areas or parental support spaces) as either extended provision or community provision, which is over and above that allowed for in the recommended gross area then additional area and funding must be found. This may be through a number of sources, see page 51.

Linked provision

In certain circumstances nearby facilities may need to be accessed by the school, such as a sports centre. The brief should identify the implications of any such linked provision. Similarly, some schools may offer a facility for a number of other local schools, for example, one school may offer a swimming pool for several schools in the area.

3: Key design requirements

The following issues should be identified in the brief as essential for any project.

Flexibility and adaptability

The flexibility to allow for change must be a key design

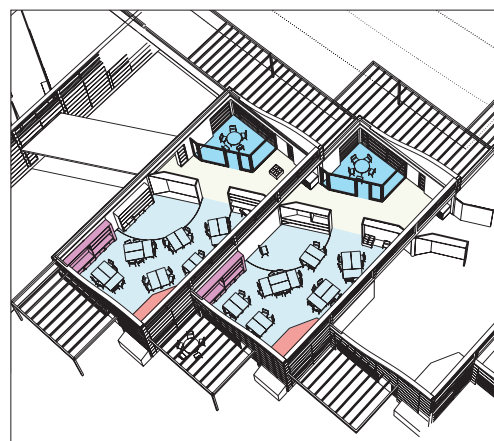

1. For instance, avoid fixed benching in your ICT suite. Use tables (fixed together and to the wall if necessary) instead, so they can be rearranged easily in the future. Limiting the range of furniture means rooms are multi-purpose and do not contain furniture which only suit one activity.

2. www.cfg.gov.uk/schoolfurniture allows the user to determine the most appropriate height for furniture based on a child's stature, age or year group.



requirement within the brief. Whatever arrangement is preferred, it must be adaptable to allow different curriculum or organisational models to be adopted in the future. What is suitable now will, as often as not, need to be changed in a few years.

It is important to be clear on the definition of flexibility and adaptability. In other words, what needs to be adaptable (for instance by changing the position of internal walls without affecting the structure or major services) and what should be flexible for more frequent change.

Adaptability is needed to allow for long-term changes, such as developments in teaching and learning methods or the implications of evolving ICT. Exact future consequences for the school are difficult to predict, but the size and number of teaching rooms may need to change and servicing requirements may alter.

Flexibility is needed to allow for different activities within the classroom or the needs of different users (reception-age children will have needs different to those of larger children in KS2). This can be achieved mainly through movable screens or furniture, which will create different classroom layouts and allow for a variety of activities to take place. Sliding partitions between rooms give flexibility, allowing team teaching for the long or short term. Some sliding doors can, however, be underused and acoustically ineffective. Effective partitions can be costly and a decision to use them must therefore be made early on in the project.

Avoiding fixed furniture as much as possible and using a standard set of plan sizes and colours in all rooms allows maximum flexibility¹. However, it will be necessary to have a number of different heights of furniture to achieve a comfortable fit for pupils, this may be achieved through adjustable height furniture². It is possible to buy furniture that can perform a number of functions, although this must be offset against the need for simple products which are easy to repair or replace.

The shape of a classroom has to be suitable for the full range of activities taking place. Rectangular shapes allow the easiest supervision and flexibility of furniture layouts. A space that is too narrow or 'L' shaped, for example, will restrict the possible furniture layouts and sight lines.

Access and inclusion

Access and inclusion in mainstream schools must be allowed for in the design, reflecting the Government's commitment to ensuring pupils with SEN and disabilities



1. Typically, pupils with speech, language and communication needs, specific learning difficulties, moderate learning difficulties, sensory impairments and physical disabilities will, as far as possible, be included in most mainstream schools. Schools with very high numbers of pupils with SEN and disabilities will require additional specialist SEN resourced provision (in supplementary area). Alternatively, there may be a co-located special school for pupils with complex needs, which will also have implications for the mainstream school. Refer to the updated BB77 Designing for SEN: Special Schools, due 2006.

2. See BB90: Lighting Design for Schools TSO 1999; (ISBN 0-11-271041-7) and BB87: Guidelines for Environmental Design in Schools, May 2003 web version, at: www.teachernet.gov.uk/energy. BB93: Acoustics in Schools is at: www.teachernet.gov.uk/acoustics

3. As defined in The DfES Guidance Note Accessible Schools: planning to increase access to schools for disabled pupils LEA/0168/2002 www.teachernet.gov.uk/sen. For details of access requirements refer to Building Regulations Approved Document M, 2004 and BS 8300.

have access to the whole curriculum and can participate in school life¹.

Particular attention should be given to:

- appropriate space for pupil support, whether educational (for instance through small-group rooms), therapeutic, social or medical;
- an easily understood layout, suitable use of colour and good signage;
- good-quality acoustics and lighting²;
- access for all pupils to the curriculum and the physical environment³ (for instance, including both a ramp and steps where there is a small change of level)

Part C recommends a range of sizes for teaching spaces that allow for pupils with SEN and disabilities and their assistants. To ensure an inclusive school the brief needs to allow for:

- multi-purpose small-group rooms for specialist teaching and pupil support;
- a medical and therapy room for peripatetic staff and health professionals;
- an interview room next to the entrance that can be used by parents and carers, as well as social services;
- accessible toilets and hygiene facilities for assisted use;
- storage space for educational and mobility equipment;
- classrooms large enough to allow for movement by disabled pupils.

Safety and security

Safety and security¹ is an overarching issue, which should be considered in conjunction with requirements for greater community access. Security is as much about creating a feeling of a secure, organised, safe environment, as it is about the specifics of surveillance and supervision of access². Particular attention needs to be given to:

- access control, for instance to ensure visitors can be shown to an interview room from reception, but cannot enter the school without permission;
- securing the building 'envelope' – walls and roofs but particularly windows and doors;
- having clearly defined site boundaries, using appropriate fencing and/or planting;
- electronic measures, such as intruder alarms or internal alarms for teachers in classrooms;

1. See *Managing School Facilities Guide 4, Improving Security in Schools*. TSO 1996 (ISBN 0-11-270916-8). Single copies available to schools from DfES Publications free of charge. Otherwise from TSO.



2. 'Secured by Design' is a police support document which gives useful tips on the design of schools. See www.securedbydesign.com/pdfs/schools.pdf
3. Defined as those which involve rebuild or complete refurbishment of more than 10% of the floor area and are valued at over £500,000.
4. The Building Research Establishment Environmental Assessment Method (BREEAM) for schools will assist in guiding school design, and should be used to assess the environmental performance of new designs. See www.bre.co.uk/breeam. See also BB87 at www.teachernet.gov.uk/energy and BB93 at www.teachernet.gov.uk/acoustics

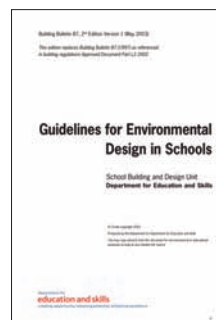

5. See BB87 at www.teachernet.gov.uk/energy
6. Ventilation standards are set out in Building Bulletin 101 Ventilation of School Buildings see www.teachernet.gov.uk/iaq
7. Refer to speech intelligibility rating and testing in Building Bulletin 93 (see above).

- a health and safety audit of the design to ensure it is appropriate for adults and pupils with SEN or disabilities.

Environmental performance

All major new-build and refurbishment projects³ should be assessed using the Building Research Establishment Environmental Assessment Method (BREEAM) for schools. The Department expects all these schemes to achieve at least a ‘very good’ rating using the new methodology. Smaller schemes may also be suitable for formal BREEAM assessment and designers should, as far as practicable, apply the same standards to all projects. The brief should require a sustainable and environmentally considered design which meets the energy performance targets quoted in the Building Regulations and is in accordance with Building Bulletin 87⁴.

Environmental performance criteria, for instance for energy⁵, ventilation⁶ and daylight are crucial. Many of these are now statutory and are vital to ensure comfortable, suitable teaching spaces. Acoustics are particularly important, and must be tested in designs that do not provide traditional acoustic separation through full height walls and doors as set out in Building Bulletin 93. Partial carpeting of classroom floors can help reduce noise⁷.

Figure C.1: Gross and net area defined.

Supplementary net area, which will be separately funded, should be added to the total net area to ensure the non-net area is increased proportionally.

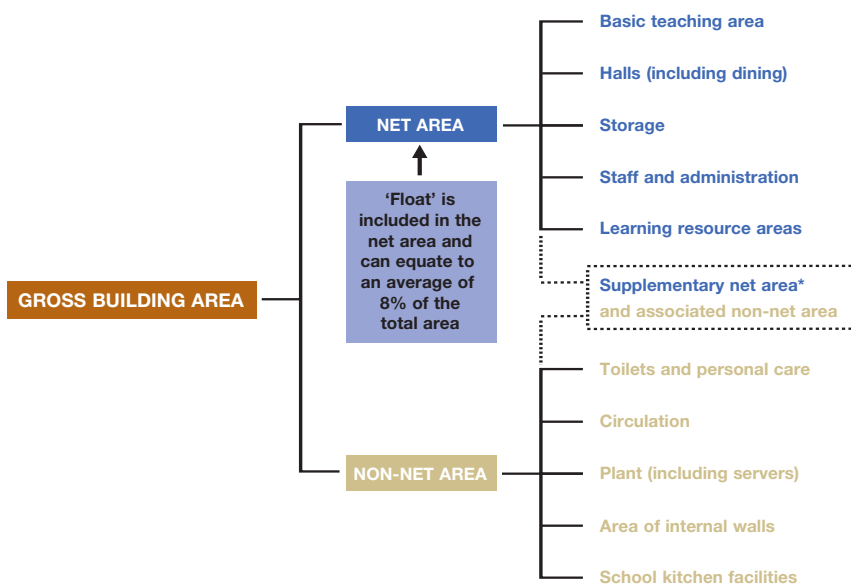

Part C: The Buildings

Determining the appropriate areas for the different components of the school buildings requires careful and methodical discussion by both the briefing and design teams. The following pages set out clear and simple guidelines for establishing the areas that will make up the accommodation schedule.

Gross area of buildings

In this document area recommendations for buildings are separated into two categories:

- net area¹, or usable area, which can be accurately calculated from the formulae in Appendix 4, plus any agreed supplementary net area; and
- non-net area, which will be more variable depending on the design, the configuration of existing buildings and site constraints, but will generally increase in proportion to the net area.

The total of these two categories gives the gross (total) area of the building, as described in Figure C.1 on page 24.

The gross area required will depend on the design and layout of buildings. Generally, the gross area of new buildings may vary between 140% and 145% of the net area (such that the net is 69% to 71.5% of the gross), depending on the layout and type of site. In existing buildings, this may rise to as much as 150%. In new buildings the gross area will need to be at least 140% of the net area², unless compromises are made in the provision of circulation space or the kitchen³.

The total net area required by an inclusive community school should not normally need to exceed the recommended net area for the number of pupil places and age range of the school as shown in Figure C.2 on page 26.

Further **supplementary net area**, and a proportional increase in non-net area, may be needed if there are specially resourced non-school or support functions on the school site (as discussed on page 51). Facilities to be provided within supplementary net area will vary widely depending on specific local needs and other available funding streams⁴.



Hint: It is important to realise that it will be the budget, rather than the gross area, which will be the determining constraint on the project. So the gross area could be larger than that recommended, as long as it is within the budget allocated and long-term maintenance commitments are recognised.

1. The net area is measured to the internal face of both internal and external walls in all parts of all buildings on the school site(s) that are intended to be secure and weather-tight, except residential or farm buildings in use as such, or buildings condemned by the LA as structurally unsafe.

2. The budget for new schools should allow for a gross area that is around 142.5% of the recommended net area.

3. Circulation may be less if routes are outside and kitchens may be smaller if they are used for re-heating food only. Conversely, circulation may need to increase in certain circumstances, such as sloping sites, to allow for ramps and kitchens may need to be large to cater for a number of schools. Both will affect the non-net area.

4. It is important that the budget allows for any supplementary area that is required over and above the recommended net area.

Figure C.2: Recommendations for total net and gross areas

Graph showing the recommended areas for total net and gross area and basic teaching. Note that the area steps in this graph are at a different scale to those in C.3.

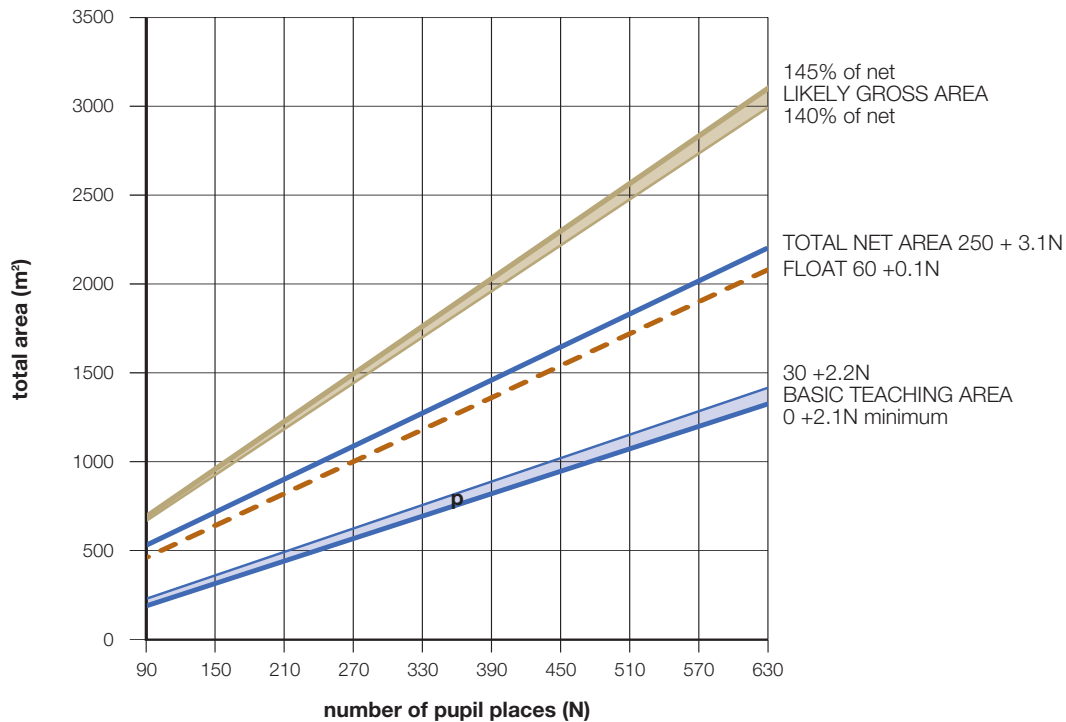

*Total Net = the sum of the minimum recommended net areas plus float.

Figure C.3: Categories of net area and related formulae

Graph showing the four remaining categories of net area and their related formulae

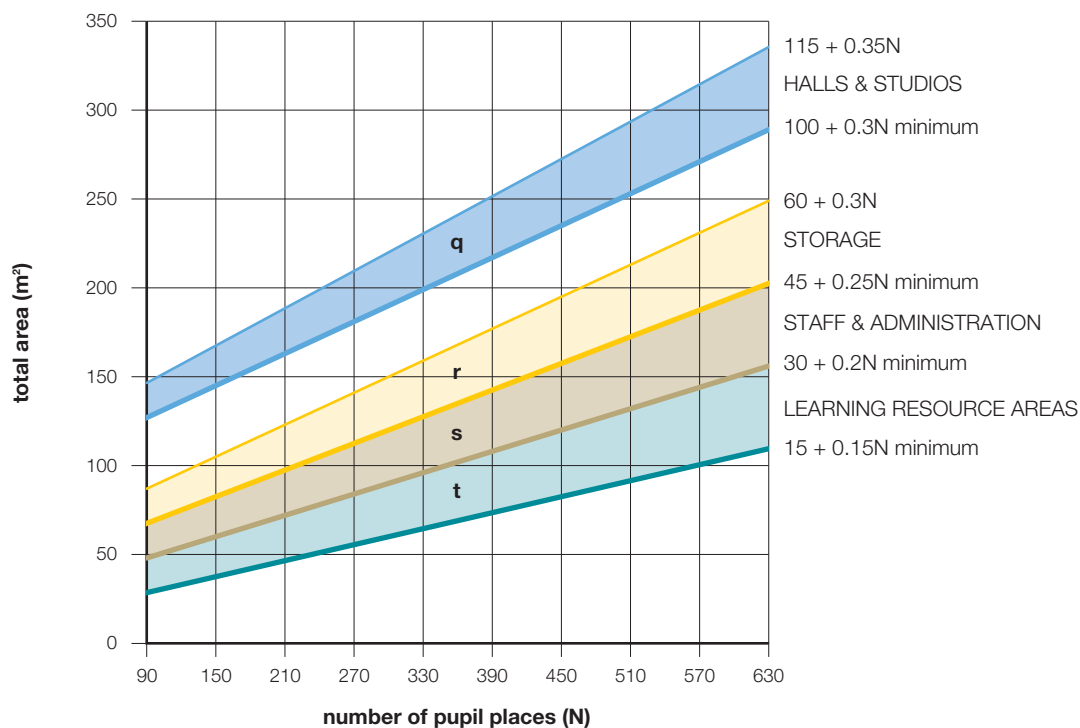

Net area of buildings

The net area is made up of the five categories of space listed below plus any supplementary net areas. In Figure C.2 and C.3, the likely area ranges of each category for all primary schools are shown as zones p to t with formulae given for each.

1. Basic teaching area (zone p);
2. Halls and studios (zone q);
3. Storage (zone r);
4. Staff and administration (zone s);
5. Learning resource areas (zone t).

The bottom of each zone, which can be calculated using the formulae shown, represents the minimum recommended area for that category of space. **The total area for each of these categories should be at least the minimum recommended in this bulletin** (i.e. the bottom of the zone)¹. If any of the individual categories are insufficient, this is likely to compromise the use of the buildings, even if the total net area is enough.

An area greater than the minimum but within the zone will usually be required for each category. The overall recommended net and gross building area, as given in Appendix 4, allows for the area of some categories of space to be more than the minimum. This is achieved through the provision of the 'float', which will help provide extra accommodation where it is most needed by each school, for instance to increase classroom size in order to be fully inclusive²; for further staff accommodation; a larger library or a changing room³. It may also be used to provide some types of community facilities if these are felt to be priorities and funding mechanisms allow it (see page 20).

Funding for major school projects will generally be based on the recommended gross area (plus any agreed supplementary areas as financed by other organisations). It is quite likely that this funding will **not** be sufficient for all categories of space to be at the top of each zone – if this is required decisions will therefore have to be made against the particular priorities of the school.

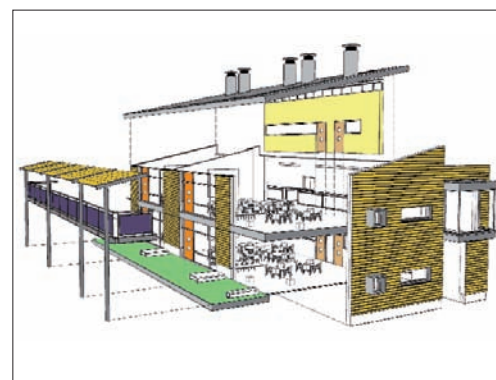

© Shephard Epstein Hunter

Hint: bear in mind that these are guidelines. The specific objectives of each school should be considered when making decisions about how much area to allocate to each activity – for instance, taking account of its priorities and ethos.

1. Split sites (where a significant part of the school is provided on each site) will generally need to use the full formulae for each site, except for halls, to allow for the replication of resources required.

2. All classrooms should allow provision for disabled pupils. However a 'fully inclusive' room should provide sufficient circulation space to allow access to all areas of the room without the need to re-arrange furniture and equipment.

3. Appendix 3 lists possible variations of area schedules for a 420 pupil school to illustrate the different uses of the float.

Nursery classes¹

Any full-time equivalent (FTE) nursery places will require the same area per pupil place for every category except:

- learning resources – recommended to be a minimum of 0.45m² per FTE nursery place;
- halls – the area of halls does not need to be increased to allow for FTE nursery places.

Schedule of accommodation

A core part of writing the brief will be to determine the schedule of accommodation. A schedule for the whole school will include spaces in all of the five net area categories (zones p to t), as defined on page 27.

This bulletin includes two sets of example schedules that can be used as a starting point.

- In Appendices 1 and 2, schedules for various typical sizes of 5 to 11 infant, junior and JMI schools show spaces listed in each of the five categories².
- In Appendix 3, different schedules³ are shown for the same size of school, showing a number of possible variations based on the school's 'proposed priorities'.

Whichever format is used, each category should be totalled and compared to the minimum recommended standard.

The next few pages give some guidance on the spaces required within each of the five categories of net area. In a design brief each category:

- **must** include spaces required by regulation;
- **should** include spaces or areas in line with best practice and non-statutory guidance;
- **may** include other spaces where appropriate to the school's priorities or preferences.



© Tim Soar

1. Overall, the total net area recommended for nursery places is the same as that for other primary school places.

2. Similar curriculum based variations for a 420-place 5-11 school with a nursery can be found in the exemplar design primary brief variations 6 and 7. See www.teachernet.gov.uk/exemplars

3. In these schedules, areas in red show the variations from the option shown in Appendices 1 and 2.

1: Basic teaching area (zone p)

Basic teaching area comprises all the teaching spaces needed for the full range of curriculum subjects¹. It does, however, exclude space for PE and some music and drama, which usually take place in the hall, studio or library.

The graph in Figure C.4 on page 30 gives area ranges for the various types of basic teaching spaces, depending on the maximum group size, which the school should identify early on in the briefing process.

The minimum size for each space, represented by the formulae at the bottom of the relevant zone, generally allows for one wheelchair user (areas towards the upper part of the zone will allow more freedom of movement around the classroom for wheelchair users) plus assistants and an increasing amount of portable ICT equipment, including projectors². The range of areas allow for local storage furniture but not for any significant coat and bag provision, which is allowed for within the storage category³.

Basic teaching area should therefore include:

- **Classrooms** (enclosed rooms)⁴ or **class-base** (and opening onto shared teaching areas on one side): one for every class (usually of 30 pupils), providing table space and a chair for each pupil, facilities for a variety of curriculum activities and teaching resources;
- **Space for a cooker:** at least a 4m² food bay where a cooker can be situated for small groups, this could be off a classroom, as part of a shared teaching area or specialist practical space (see below).

Basic teaching area may also include:

- **Shared teaching area:** shared by groups from two or three adjacent class-bases, (and usually able to be partially supervised by the teacher from each class-base) to allow some facilities, usually for practical work, to be shared rather than provided in every classroom;
- **Specialist practical spaces:** enclosed rooms fitted with specialist equipment and shared by a number of classes, it may encompass the area required for a cooker;
- **ICT room/base:** if the school prefers a separate space where all or half a class can use computers (see page 37).

A cluster of classbases and shared teaching area will usually also include a small group room (covered under learning resources area, see page 43) and storage (page 40).



Hint: To allow for long-term flexibility, it is advisable to use a maximum group size of 30 for all class-bases, 10 to 15 for specialist practical areas/spaces, usually 15 or 30 in an ICT base⁵, up to twelve for shared teaching areas and 4 to 6 for group rooms, depending on the size of the school⁶.

1. What is 'basic teaching area'? This is defined as all types of learning areas other than halls and studios and learning resource areas. These will include the class base; group rooms; ICT bases, practical areas and shared teaching areas. Some of these spaces may be enclosed, others open, and activities carried out within them will vary from school to school.

2. In small schools it can be uneconomic to design specialist areas for 30 pupils. Where the number of classes is low (say below 10 classes), the ICT suite will not be well used unless it is also designed for other, additional purposes.

3. Generally any furniture over 2.1m in height counts towards the storage category.

4. In the schedules in Appendix 1 and 2, all classrooms are at least 57m². This is also the size used in the primary exemplar designs see www.teachernet.gov.uk/exemplars

5. Zone D on Figure C.4 gives the range of area for an ICT suite.

6. ICT suites and specialist practical spaces will be defined in any net capacity assessment as 'specialist', and not count towards the capacity of the school. See Assessing the Net Capacity of Schools DfES/0739/2001. www.dfes.gsi.gov.uk/netcapacity

Figure C.4: size of teaching spaces and group rooms

Graph showing zones of recommended area for basic teaching spaces (zones D-B) and small group rooms (zone A). The bottom of each zone represents the minimum size recommended for the group size, and can be calculated using the formulae shown.

zone	function
D	large classroom (recommended minimum for foundation stage), Information Communication Technology (ICT) suite, specialist practical areas such as creative space (art and design and technology) or science;
C	standard classroom (recommended minimum for KS1 and 2);
B	small class-base (should be used in conjunction with shared teaching areas);
A	small group room, as identified in learning resources provision, see page 43.

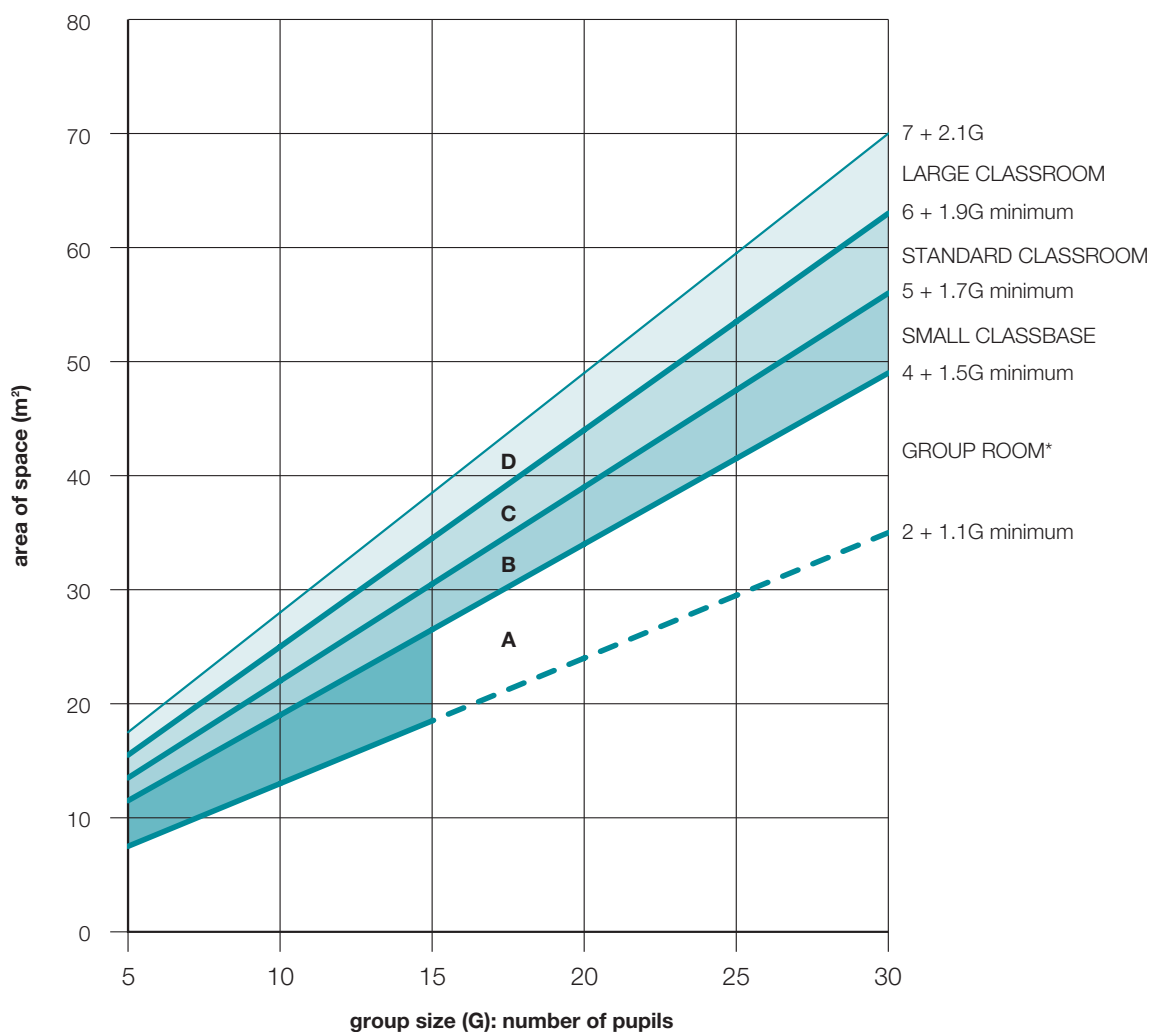

* zone A: group room is not included as part of basic teaching

Classrooms or classbases

Figure C.4 shows how classrooms or bases can be split broadly into three size bands which are:

- zone D: Large classroom areas of 63m² to 70m², each with designated space for practical work and up to four networked computers¹ (either PCs or laptops). This will allow sufficient space for wheelchair users to access all activities and specialist equipment. Positioned on one side of a circulation route or learning resource area, large classrooms can suit a variety of provision for different schools and for future learning options in Key Stage (KS)1² or 2. Using the top of the range is particularly recommended for foundation stage classes in new or remodelled schools.
- zone C: Standard classrooms of 56m² to 63m² will accommodate most activities and at least two networked computers, but will need to be supplemented by a timetabled specialist practical space, for instance, of 36m² for half a class. This size is recommended for all KS1 and 2 classes in new or remodelled schools, with the top to mid-range used for 'fully inclusive' classrooms.
- zone B: Small classbases of up to 56m² will accommodate the activities crucial to numeracy and literacy. Small classbases will need to open onto a shared teaching area to provide other key facilities such as a wet area or book corner³. If shared areas also accommodate different practical activities, then they can be timetabled for use by other class groups when appropriate. This arrangement works best in 2FE⁴ schools where similar activities are being carried out by both classes⁵. The diagrams in the outer margin show various options. In these examples, shared areas are directly located off the classbase. Alternatively Figure C.5 on page 32 looks at shared areas off corridors.

As part of the research for this document, activities for each key stage were identified. These activities can be accommodated in a variety of spaces within the basic teaching area category, depending on the preferences of the school. Figure C.6 (on page 34) lists the different activities that need to be accommodated either in the classroom or in the classbase and adjacent shared teaching areas. Mobile furniture and changes in floor finishes will help to informally demarcate different zones for the various activities that may overlap. Furniture will vary in size and need depending on the age range.



1. Assuming cathode ray tube monitor etc. on 1200mm x 700mm table.
2. **What is a Key Stage?** A key stage is a specific part of child's education and relates to their age and year group.
3. Not including supported work with assistants that might take place in small group rooms (within learning resources area).
4. **What is 2FE?** FE means 'form of entry', in other words the number of classes of 30 in each year. 2FE would therefore be two classes and result in 60 children in each year.
5. A number of arrangements are available for shared areas across pairs of classrooms:

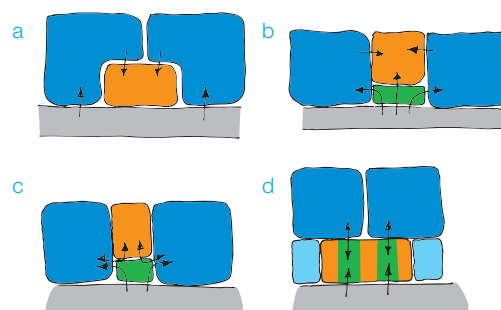

- Key:
- = classroom
 - = classroom shared area
 - = classroom circulation
 - = classroom secondary circulation
 - = classroom store/group room

- a: Single access to the shared area maximises usable space. Classrooms are accessed from the corridor only and 'wrap' around the shared area – this can, however, create a difficult classroom shape.
- b: Access to both shared area and the classroom is via a secondary circulation lobby. Additional direct access can be gained from the classroom for ease of supervision.
- c: A narrow shared teaching area is accessed only via the secondary circulation lobby, as are classrooms. This keeps the corridor clear for display, etc.
- d: A shared teaching area opening onto the corridor is flanked either side by storerooms. Secondary circulation into the classroom leaves little usable space in the shared area.

Figure C.5: Six classroom options

This diagram shows three ways of accommodating 6 groups of up to 30 pupils using a basic teaching area of 378m²:

- six classrooms of 63m² (the top of zone C)
- six classrooms of 57m² (the bottom of zone C) with a shared ICT suite
- six class bases of 49m² (zone B) with access to shared learning areas.

Each option also provides a shared resources store, small group room (SGR), a 4m² store or 'food bay' and circulation space.

The diagram also demonstrates that one option could be changed to another by repositioning partition walls but without altering toilet, window or door positions.

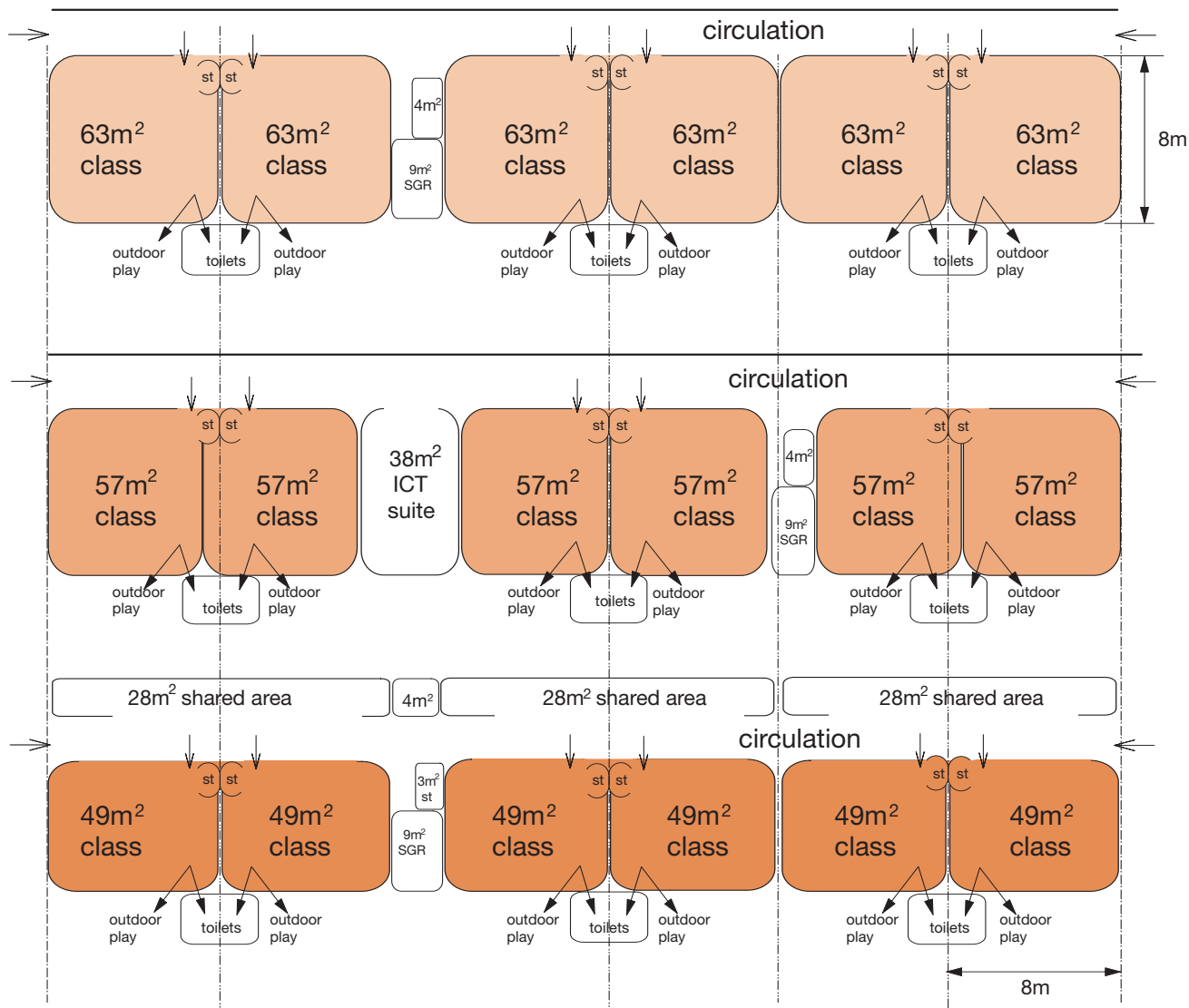

As an initial exercise, before detailed layouts are determined, 'blocks' of activities can be identified. The diagrams in the outer margin illustrate the activities that take place in classrooms for reception age children; key stages 1 (years 1 and 2); 2a (years 3 and 4) and 2b (years 5 and 6). The diagrams relate to the detailed layouts in the margin of page 35, the list in Figure C.6 and the points covered on page 31.

For the purposes of classroom layout arrangements KS2a refers to years 3 and 4 where activities are sometimes similar to those of 1 and 2. KS2b refers to years 5 and 6 where a more formalised approach is often appropriate.

a: reception class most often requires a large carpeted area to allow a whole class to sit together and carry out some aspects of numeracy and literacy as well as other activities such as group discussion and story telling. Next to this is a second carpeted, quiet area where pupils can listen to music tapes or read books. The two areas can be separated by mobile storage units and used together to increase gathering space when necessary. A teaching focus is shown, however some schools may feel a mobile board on the carpeted area is sufficient. A role play zone (or home corner) allows pupils to learn through play. Formalised layouts are not generally necessary, and very often table and chair positions are not required for a whole class.

b: KS1 and 2a classrooms also require a carpeted area, which can double up as quiet space for reading or large-scale construction work. The role-play area provides a space to create, for example, a 'shop' or 'post office' where children can learn about money, transactions and services. Some schools may feel this area is not necessary, however. Chairs and table positions for each pupil will be necessary.

c: KS2b classrooms require a small free area for construction kits etc., but this can double up with the area required in front of the whiteboard (teaching zone). As lessons are more formalised at this stage, pupils will need to see the whiteboard easily, which restricts table layout possibilities. Some schools prefer a formalised table and chair arrangement. A reference book area is provided for books relevant to a particular topic being covered.

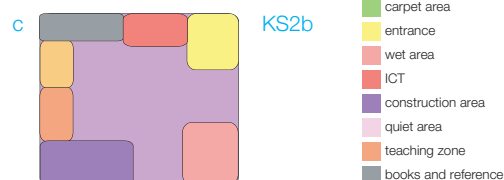
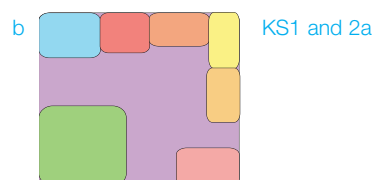
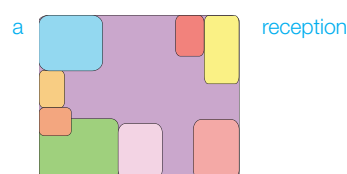

- KEY:
- teachers base
 - role play
 - carpet area
 - entrance
 - wet area
 - ICT
 - construction area
 - quiet area
 - teaching zone
 - books and reference



Figure C.6: Activities to be accommodated in the classroom or classbase.

All those activities marked as required can be accommodated in the minimum recommended size of small classroom (the bottom of zone B). Activities marked as preferred or optional will generally need a standard classroom (zone C), while four computers or further tables for wet and messy work will require a large classroom (zone D).

Activities	Facilities ¹	Foundation	Y1 and 2	Y3 and 4	Y5 and 6
Group discussion, whole class teaching	whiteboard, interactive screen or similar	required			
Literacy, numeracy, other subjects	adequate table space, generally arranged in groups (half table per pupil assumed)	for 1/3 to 2/3 of class	required for whole class		
Group discussion, literacy and generally not required numeracy, whole class activities, storytelling	free floor space, usually on a carpeted area, for gathering the whole class together sitting on the floor	required	one area used for both	one area used for both	generally not required
Large scale construction kits, practical 3D work, some ICT work using robots etc.	[smaller] free floor space for space-consuming work on the floor, including large-scale construction	required			required
Individual or group reading/research	a book corner or quiet area with room to browse, and cushions (with the option to overlap with the free floor area if small class-base in zone B)	required	preferred	optional	not required
For creative play and role play	space for creative play and role play	required	preferred	not required	not required
individual, group or whole class ICT based work	desktop computer workstations or laptops (see page 37)	1 to 2	2 to 4 depending on other ICT available		
Individual AV music or language work	audio-[visual] resources (overlapping with book corner)	preferred	preferred (if available)	optional	not required
Group or whole class music activities	music resources, on trolleys or out on permanent display	optional	optional	available elsewhere	available elsewhere
Drawing, sketching and working with 'compliant' materials such as fabric and cardboard etc.	resources for 'dry' practical activities, using the tables available, such as making and testing	required			
2D and 3D science, art and design technology work using paint, glue, sand, water etc.	sink, washable floor area and resources for simple 'wet' practical activities	required	required (may be in shared teaching area)		
2D and 3D design and technology work using resistant materials such as wood and some plastics	further tables or fixed side benching and sink and resources for wet and messy work, some 'heavy duty' tables for hand tool work	required	optional (may be in shared teaching area)		
All activities as identified above	space for wheelchair user, specialist appliances or equipment and possible assistant	required			

¹. For information on furniture and equipment specifications please see 'Furniture and Equipment in schools: A Purchasing Guide' or download it at www.teachernet.gov.uk/schoolfurniture

Having established the kinds of activities required by the school, more specific layouts can be drawn up. The classroom layouts in the outer margin show the furniture and equipment related to the activities identified in Figure C.6 and the diagrams on page 33. In all examples the areas are at the top of zone C as shown in Figure C.4. This allows for greater circulation for non-ambulant pupils to key areas of the classroom. The coloured lines indicate the circulation routes associated with typical classroom activities.

- a: standard classroom at 70m² for 30 reception pupils.
Tables and chair positions are shown for each pupil, although there is less worktop area than for older pupils'. A role play area in the corner provides 'home corner' furniture. More free space is allowed around the sink and an external door is located nearby for messy work to take place outside. Circle time and quiet, individual work are shown on a shared carpet area, which, if furniture is moved, could be used as one space.
- b: standard classroom of 63m² for 30 KS1 and 2a pupils.
Here, two computers provide network access. A role play area is shown. A carpeted area allows for circle time and gathering space around the whiteboard etc.
- c: standard classrooms of 63m² for 30 KS2b pupils. A small carpeted area allows for floor based construction work and space for pupils to gather in front of the whiteboard. Two networked computers and a run of shelves and racks for books create a reference area.
- d: shows a more formalised layout which may be preferred for some activities in years 5 and 6 (KS2b), using the same furniture as (c) above. Here all pupils face the whiteboard.

a: standard classroom at 70m² for 30 reception pupils.



b: standard classroom of 63m² for 30 KS1 and 2a pupils



c: standard classroom of 63m² for 30 KS2b pupils.



d: alternative layout of (c).



Shared teaching areas

A shared area is often located alongside two or three classbases, as shown in Figure C.5 and the diagrams on page 31, where it provides additional space away from the classbase but easily supervised. As it is essentially an open area it should be possible for it to be supervised from adjacent classbases, so that pupils can spill out of their classbases for additional activities. It often houses messy, practical activities and is therefore often equipped with a sink and fixed standing-height benching.

Historically a shared area has often doubled up as a circulation route to classrooms. For most effective use of the space, however, it is recommended that it is distinct from any circulation, enabling pupils to use the space freely without distraction. Using the range given in zone A, up to 12 pupils can be accommodated in the area, although the area given at the bottom of the range may offer few opportunities for anything other than a standing-height worksurface with sink and one large table. A shared area may also provide ICT facilities if the school feels using ICT is an appropriate activity for pupils to carry out without direct supervision.

Specialist practical spaces

The practical activities needed to teach science, design and technology and art, (i.e. scientific experiments, food preparation, control technology and large-scale constructions) can take place in large or standard classrooms; 'practical shared teaching spaces shared between two or three smaller classrooms; or specialist teaching spaces as shown in the margin.

Recommended areas for such specialist spaces, which should be accommodated within the total basic teaching area (zone p), are in zone D as shown in Figure C.4. These spaces allow specialist resources that would be difficult, costly or impractical to provide in every classroom.

Specialist practical areas have often been designed for groups of six to eight pupils. This may continue to satisfy the teaching methods of the school, for instance if groups of pupils carry out different activities within the same project. Nowadays, however, these spaces are likely to be more effective if they are large enough for half a class.

The diagrams in the outer margin show how one space of 38m² can accommodate one or more specialist practical activity, using different furniture and equipment to create a variety of environments for up to 15 pupils.



a: 38m² room for art and design technology.

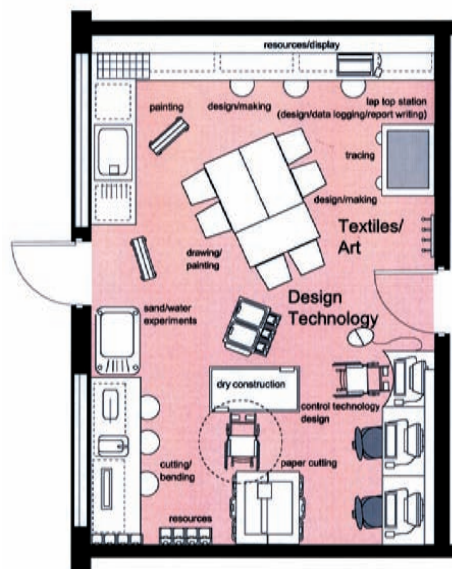

b: 38m² room for food and science activities, this may include the 4m² allocation for a food bay.

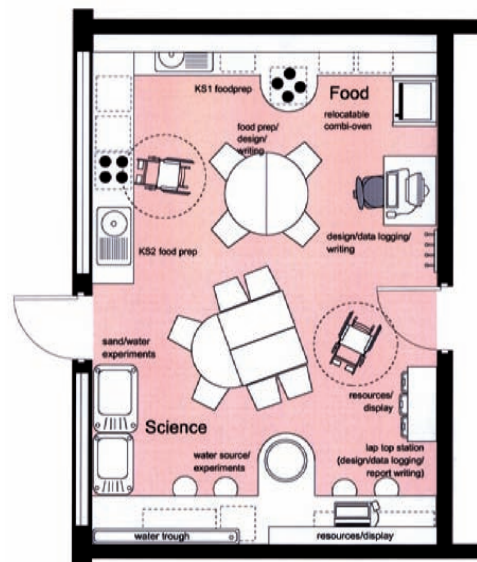

If the school requires a specialist practical area, its location should be determined early on. Discrete rooms will require a teacher in attendance, whereas practical 'open' bays will allow partial supervision by a teacher or assistant, depending on the activity. Discrete rooms allow for better use of space (more wall space is available) and concentration by pupils but must only be introduced if the school feels it can provide teaching staff to operate them.

ICT bases

Currently, the most common configuration is for some formal ICT to be taught to a whole or half-class group in a separate room with a provision of 15 to 30 desktop computers. Zone D in Figure C.4 gives area ranges for this space. Other ICT activities are usually carried out either in classrooms, as they allow the teacher to monitor pupils more closely, or in shared teaching areas group rooms in more informal areas, such as libraries and bays in corridors. In larger classrooms, battery-operated laptops can be used, with a bank of desktops providing occasional internet access. However, as technology becomes more reliable and electronic whiteboard use more widespread, some schools are choosing to use portable and wireless technology to teach a whole group of 30 pupils in the classroom. The provision of 30 laptops has little effect on the size of the classroom but may affect storage provision. Such an approach should be determined early on in the briefing process (see page 19).

The type and location of ICT used by pupils will have an impact on the overall design of the building, both now and in the future. If an ICT suite is preferred, it can be used for something else later in the future if wireless laptops or tablets are eventually to be used in the classroom. As laptop and tablet computers take up little space, the room currently required as an ICT base can be usefully converted into a specialist practical space in the future – particularly if it has services such as water and drainage readily available.

The diagrams in the outer margin show two layout options for an ICT room that at 38m² can be adapted for future specialist practical use if the school's approach to ICT learning changes. The layouts assume use by half-class groups of 15.



Hint: if ICT, practical and music activities are accommodated in timetabled spaces, the minimum size of classrooms can reduce as the age increases. In projects using existing provision, therefore, it would be sensible for the later year groups to be in the smallest classrooms and vice-versa.



a: Perimeter based layout with a central 'free' area for demonstrations, notes and discussion.

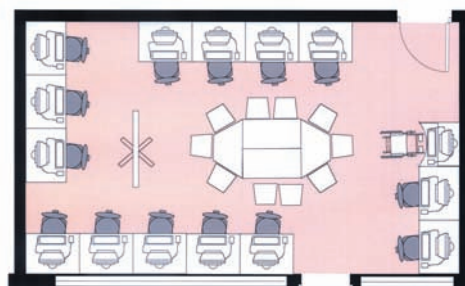

b: Peninsula based layout, here teaching and demonstrations can be done at ICT tables.

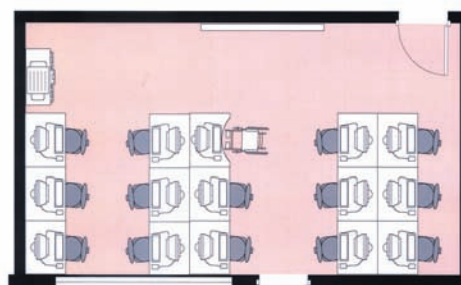
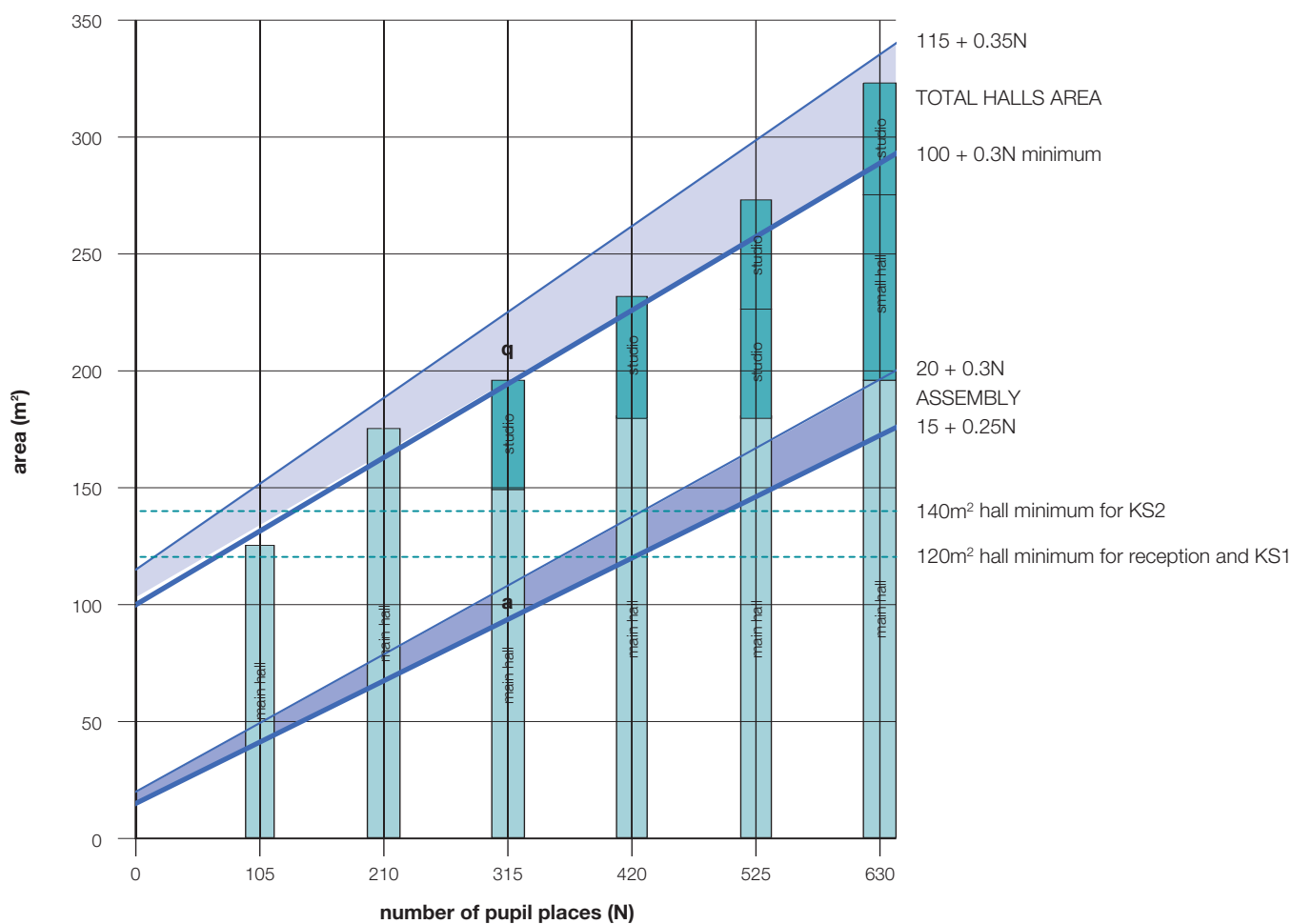

Figure C.7: sizes of halls

Graph shows the recommended area for halls for any primary school. Zone a shows the area needed for assembly, with the bottom of the zone being the minimum for infants and the middle of the zone the minimum for juniors to assemble. The graph can be used to show how many pupils can assemble in a hall. For example in a 630-place school a minimum KS2 hall of 140m² – which can accommodate up to 450 pupils – would be sufficient to assemble all 360 KS2 pupils but a hall of 190m² would be needed to assemble the whole school at the same time. The dotted lines show the minimum size of hall for PE for both infants and juniors. Zone q shows the total halls area with the graph as a whole indicating the possible breakdown of this allocation.



2: Halls and studios (zone q)

Halls and studios are unfurnished spaces that have particular height, finish and acoustic criteria, and blackout facilities where necessary.

In any primary school, the total area for halls and studios should include at least one hall or studio for every 200 pupil places. This should include: a main hall¹ of at least 120m² for infants or 140m² for juniors, sufficient for PE and dance (ideally with a sprung floor and some wall mounted PE apparatus), assemblies of the whole school at one time (as in zone a opposite), public performances, parents' evenings and community events;

And might include:

- a small hall² of at least 80m² for PE without apparatus;
- an activity studio of at least 45m², for music, drama and 'circle time'
- a dining space, as discussed below.

The graph in Figure C.7. shows how these spaces could fit within the recommended zone for halls in primary schools.

These spaces may also be suitable and popular for community use, and this should be considered when specifying their location and other requirements. The hall is also likely to be used for dining, and will need a servery and kitchen adjacent (see page 49).

Where the space within zone q permits³, or where further funding is available, the main hall can best suit community use outside the school day by being a 'one-court' 180m² sports hall designed to Sport England's specifications⁴, including the critical minimum dimensions for a badminton court of 18m x 10m x 6.1m high⁵;

In some sizes of school, decisions need to be made as to the use of the 'float' area⁶, which may be used to contribute to the main hall and create a 'one-court' sports hall.

The briefing team should consider where pupils will eat lunch, and the type of catering that will be provided. In a 420-place school, the second hall or studio space is needed because the hall is assumed to be out of use for around 30% of the school day for setting up and serving lunch. However, it could be available full-time and the studio space, and/or classrooms could be used for dining⁶. In a 630-place school, the studio and small hall may be used, but this will depend on the location of the kitchen.



Hint: Health and safety considerations should be paramount and close supervision is normally required. Wherever possible furniture and equipment should be of an appropriate size for the age range.

1. See 'Inspirational Design for PE and Sports Spaces' 2005, DfES (ISBN 1-84478-637-4).

2. Halls are generally over 75m², with high ceilings. See net capacity guidance at www.dfes.gsi.gov.uk/netcapacity

3. As in Appendix 3.

4. Refer to Sports England Technical Guidance Notes and 'Designing space for sports and arts'. See www.sportengland.org/resources/resource_downloads.shtml



5. A larger area may be provided for some uses if further funding is available. See Sports England guidance notes 'Sports Halls: Sizes and Layouts' (ISBN 1-86078-108-X) and 'Sports Halls: Design' (ISBN 1-86078-094-6). Alternatively, a smaller space can be used for some community uses but not badminton.

6. See page 1, note 2.

3: Storage (zone r)

The area of storage must include coat and bag storage for all **pupils' personal belongings**, equivalent to at least 3m² per class¹. Coat and bag racks may be located in classrooms, in separate cloakrooms or in corridors². The location is also determined by the routes used to access classrooms from the playground.

Total storage areas should include the following **teaching storage**:

- **full height, lockable storage**³ of at least 1m² for every classroom⁴, easily accessible by staff (but not pupils), for resources such as valuable or hazardous items;
- **specialist walk-in stores** for shared curriculum resources: at least two 6m² storerooms in any school, accessible ideally from a corridor or shared teaching area, for numeracy, literacy and practical subjects such as science, design and technology and art;
- **indoor and outdoor PE equipment storage** opening onto the long side of the main hall and accessible from outdoor PE facilities, totalling at least 10% of the area of the hall⁵.

It is important that defined teaching storage is provided to avoid the usable area and flexibility of the teaching spaces being compromised⁶.

Other **non-teaching storage** should include:

- **secure storage** for valuable items such as school and personal records, usually located off or near the school office;
- **central storage for disabled pupils'** mobility equipment and aids and for storage of bulk stock, such as pens or paper or staging;
- **storage for maintenance equipment** and cleaners' and caretaker's equipment;
- **a chair and table store** when the hall is used for dining. This may be positioned between the kitchen and hall, and can double up with the servery.

And may include:

- further separate storage for community use if appropriate. This may include lockers and long-term equipment storage, for instance if the hall is to be used for sports activities out of school hours. An additional resources store may be required if after school/holiday clubs are run by separate providers.



1. The Education (School Premises) Regulations 1999 require schools to provide ... "appropriate ancillary facilities in particular: (a) for the storing and drying of pupils' outdoor clothing and for storing of their other belongings."
2. For fire protection reasons ideally in circulation routes that are not dead ends.
3. Full height storage or storage units above 2.1m high, whether in the form of furniture units or walk-in stores, should be classified as storage in any schedule of accommodation or capacity calculation and count as non-teaching area for the purpose of area calculations. Full height storage, such as lockers, coat and bag stores or cupboards, should be counted as storage area rather than teaching area.
4. Most teaching resources in the classroom will generally be stored in additional low level furniture, allowing access for both teachers and pupils, and also allowing plenty of top surfaces for the display of resources or work. The DfES Furniture and Equipment guide gives advice on furniture issues at www.teachernet.gov.uk/fande
5. This is a minimum figure. Sports England recommends 12.5% and a minimum of 45m² for a one court hall. Note fire containment issues for mat storage.
6. For instance by PE equipment permanently stacked in the hall.



4: Staff and administration (zone s)

The staff and administration area sits mostly within non-teaching area. The diagrams in the outer margin look at layout options for these spaces. The total staff and administration area must¹ include:

- an **office** for the head teacher of at least 10m²;
- a **medical inspection (MI) room**, which may also be used for visiting therapists or other support for pupils with SEN and disabilities, if there is a separate ‘sick bay’;
- a **work and social space** for teaching staff, usually in the form of a central staff room for work and social use. Diagram a in the outer margin of page 43 shows a notional layout for a combined space with designated ICT area and free tables for laptop and general work. Storage units for teachers’ personal possessions and papers can be included, particularly for visiting staff who may not have a class base, however this will depend on the school’s policy.

Staff and administrative area:

- **offices** for other senior teaching staff, such as the deputy or assistant heads, who may need privacy for interviews and pastoral support;
- a **main office** for administrative staff, with storage space for confidential records and a link to reception;
- a **secure reception area**, with access to the rest of the school controlled by the office staff;
- separate **reprographic** facilities².

It may also include:

- an **interview/meeting room**³, ideally adjacent to the entrance foyer so that it can be used by visitors without them entering the main school. This could be linked to or shared with a parents’ room;
- a **caretaker’s office**;
- a **‘sick bay’**, near to the reception and main office, for pupils who are ill and waiting to be picked up (this is different to the MI room above).

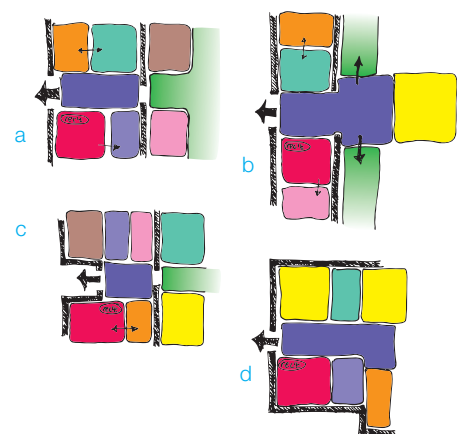

Key:

- | | |
|-----------------------------------|---------------------------|
| ■ = general office with reception | ■ = MI/therapy room |
| ■ = headteacher's office | ■ = sick bay |
| ■ = interview/meeting room | ■ = staff room |
| ■ = parents room | ■ = primary circulation |
| | ■ = secondary circulation |

- a: A reception area is flanked by the office and headteachers room. The headteacher's room has a moveable acoustic partition link to a larger interview room for staff or parental meetings. A secondary circulation area provides security for the rest of the school, here, parents who participate in school activities and visiting medical staff can be accommodated.
- b: A reception area opens out into a circulation area to the rest of the school. A separately secured secondary circulation route is not shown. Administration areas run along the front of the school, a staff room is located further into the centre of the building.
- c: Reception sits by the main entrance, linked to the headteachers office. A secure secondary circulation area has the staff room and meeting room off it, the meeting room could act as additional space for staff when required. A parents' room sits at the front of the school for ease of access.
- d: This layout does not show a secondary entrance to the school. Here, the staff room is at the front of the school, offering a link with admin and the Headteacher. The staff room is split between a work area (at the front) and a social space, in between is a meeting room, which is linked via moveable acoustic partitions so as to create a large space for whole staff meetings and functions.

1. The Education (School Premises) Regulations 1999 require any primary school with over 120 pupils to have an office for the head teacher, and all schools to have an MI room and space for staff to work and socialise.

2. Reprographic facilities, and possibly ICT printing services, can usefully be positioned in a central room (but not in circulation areas) with adequate ventilation, if appropriate staff are available.

3. If there is a meeting room, the head's office may be less than 10m². A separate meeting room has the advantage that it can be used while the head's office is occupied.

Figure C.8: total area of learning resources

Graph showing recommended learning resource area for any primary school (zone t). The dotted line indicates the minimum area for a single library, which is counted within zone t.

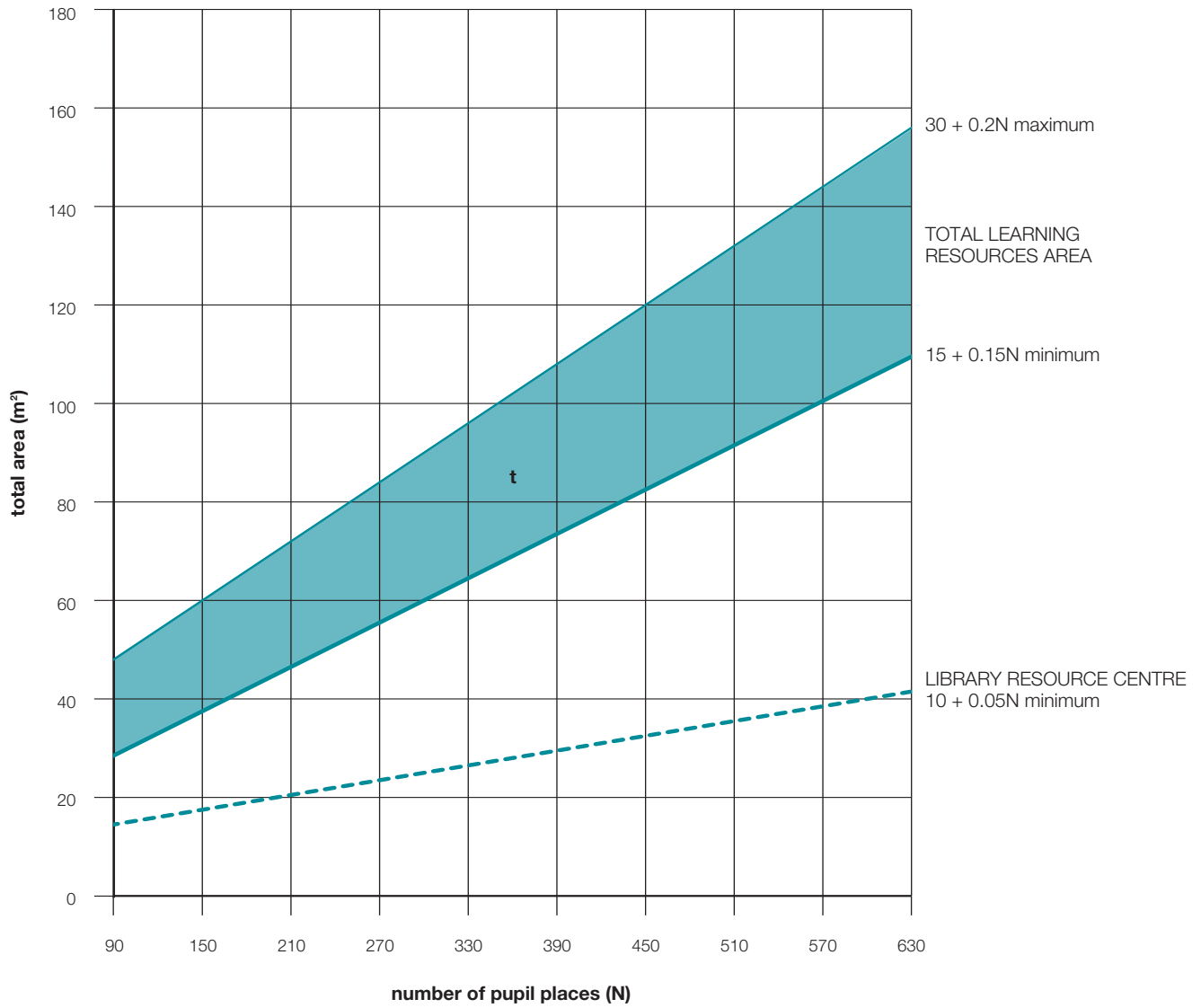

Staff room

A staff room is usually centrally located and often provides both a work and social space. Alternatively there may be separate work and social spaces. A combined space does, however, tend to be more efficiently used. The diagrams in the outer margin show two different approaches to staff provision, one which allows work to be carried out in the staff room and one which presumes most staff work is classroom-based but has provision for whole staff meetings and socialising.

5: Learning resource areas (zone t)

Figure C.8 (previous page) and C.3 on page 26 shows the total recommended area for all learning resources for any primary school (zone t). The higher end of the range could apply to a school with a large number of specialist support spaces, or small group rooms, to suit a high level of inclusion. Figure C.8 also shows the minimum area for the library resource centre as a separate entity for any primary school.

Learning resource areas are generally spaces used for informal learning and shared by the whole school. The total area for this category of space should include:

- at least one **library** totalling a minimum of 10m² plus 0.05m² for every pupil place;
- one **small group room** for the SEN co-ordinator to use as a resource area for learning, that will accommodate facilities away from the classroom for up to six children to work with a teaching assistant, peripatetic teacher or counsellor;
- a further **small group room** for the nursery, where there is one, for quiet activities such as storytelling or withdrawal of individual children.

Learning resource areas may also include:

- further small group rooms for four to six children to work with teaching assistants, spread around the school to serve every three to four classrooms;
- a specific **SEN resource base** for learning, behaviour, therapy support and case conferences. This room may be needed where there is a high level of SEN in a large school, or where there is not an MI room available for therapy or case conferences. It would generally be towards the top part of zone A for up to 10 pupils (see Figure C4, page 30).

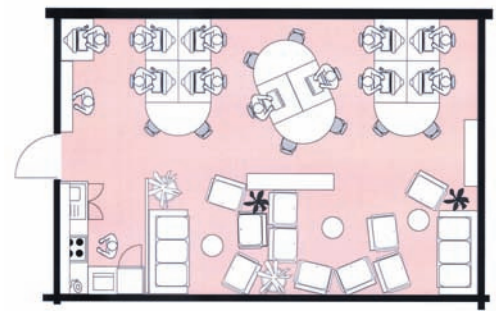

a: A combined staff and social space suitable for a 420-place school, assuming no more than 30 staff using the space at any one time.

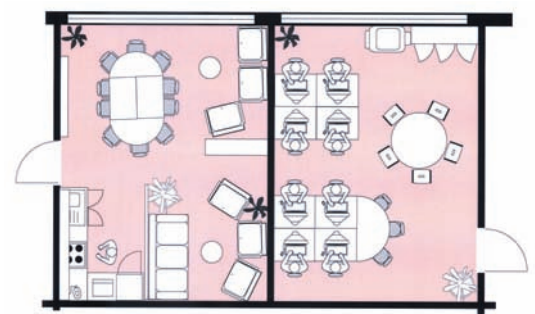

b: Separate social and work spaces allow teachers to work without distraction in non-contact time during the day. Here it is assumed that no more than 20 staff will socialise at any one time. However, provision is made for up to 30 to gather for occasional meetings.

Hint: part-time and peripatetic administration staff may share the same workstation if they each have separate storage space.



Library

The library, or learning resource centre, will include books, maps, CD-ROMs and artefacts available to the whole school¹.

A school may choose to provide one library, or to disperse several areas around the school. Alternatively they may choose to provide two libraries, one for the infants and one for juniors. Providing separate areas can, however, lead to duplication of resources and staff – this must be weighed against the accessibility, supervision and ownership advantages of local resource areas.

Small group rooms

These rooms usually provide an enclosed space for small groups (usually of around four to six pupils) with a teaching assistant, peripatetic teacher or counsellor, or for particular pupils to use as a quiet space. Small group rooms, which are particularly important for the inclusion of pupils with SEN and disabilities, could be dispersed throughout the school and ideally accessible directly from adjacent teaching spaces. Alternatively, they may be centrally located for ease of access for all and sharing resources. They should be enclosed, preferably with a door, to suit the range of likely activities and may be needed to be used on an ad-hoc basis. Areas recommended in zone A in Figure C.4 should be used.

One small group room might suit a group of six while any others may be slightly smaller. Larger group room sizes will usefully increase the range of uses but will use some float.



Hint: Some schools in the past have provided an enclosed large group room for floor-based work, in lieu of carpeted areas in classrooms, shared by two or three classes. This would count towards basic teaching area (ultimately taking space away from the classrooms). Zone A in Figure C.4 would suit this large group room, but it would not easily accommodate the activities currently required for numeracy and literacy, particularly as it is usual to teach them in whole class groups.



1. For more information see Cambridgeshire library service at <http://www.cambridgeshire.gov.uk/leisure/libraries>

Non-net area of buildings

The non-net area comprises the five categories of space listed below:

- 1: Toilets and personal care (zone M, page 48);
- 2: Kitchen facilities net¹ (zone K, page 48);
- 3: Circulation (20% to 25% of net);
- 4: Plant, such as boilers (2% to 4% of net);
- 5: The area of internal walls (4% to 7% of net).

The first two categories of space will depend on the number of pupils, community use and, for kitchens, the type of catering arrangements in the school. The last three categories will generally be directly proportional to the net area, and as such, are presented as a range of percentages of total net area. It is therefore important to include any supplementary net area in the total net area before calculating the requirement for these areas although some of these areas may be funded from other sources.

The total area for each of these categories should be at least the minimum recommended in this bulletin.

However, if any of the individual categories are insufficient for the site (even if the total non-net area is enough), or if some categories are disproportionately large, **this is likely to compromise the best use of the buildings.**

An area greater than the minimum but within the zone or range above will usually be required for each category. The overall recommended gross area of between 140-145% of the total net area (such that net area is between 69-71.5% of gross) allows for the area of each category of space to average around the middle of each zone.

1: Toilets and personal care

The total area of toilets and personal care facilities (zone M) must include:

- **pupil toilets:** at least one for every 20 pupils aged 5 to 11² and one for every child (or full time equivalent nursery place) under 5. In primary and middle-deemed-primary schools, the number of washbasins should equal the number of sanitary fittings in each washroom;
- separate **staff toilets:** two for the first 25 full-time equivalent members of staff and another one for every further 25³ (not including catering staff). In the case of a small school with a majority of female teachers it may be an option to make one of the two toilets unisex;



¹ zone K does not allow for a servery area

² The Education (School Premises) Regulations 1999 require one toilet for every 20 pupils of 5 or above (rounded up to the next whole, even number).

³ Appropriate provision for staff is suggested in the Workplace (Health, Safety and Welfare) Regulations 1992, Approved Code of Practice.

Figure C.9: Non-net areas

The graph shows approximate recommended standards for non-net areas, assuming no supplementary net area. Zones in the graph are based on a percentage of the recommended net area, as on page 26.

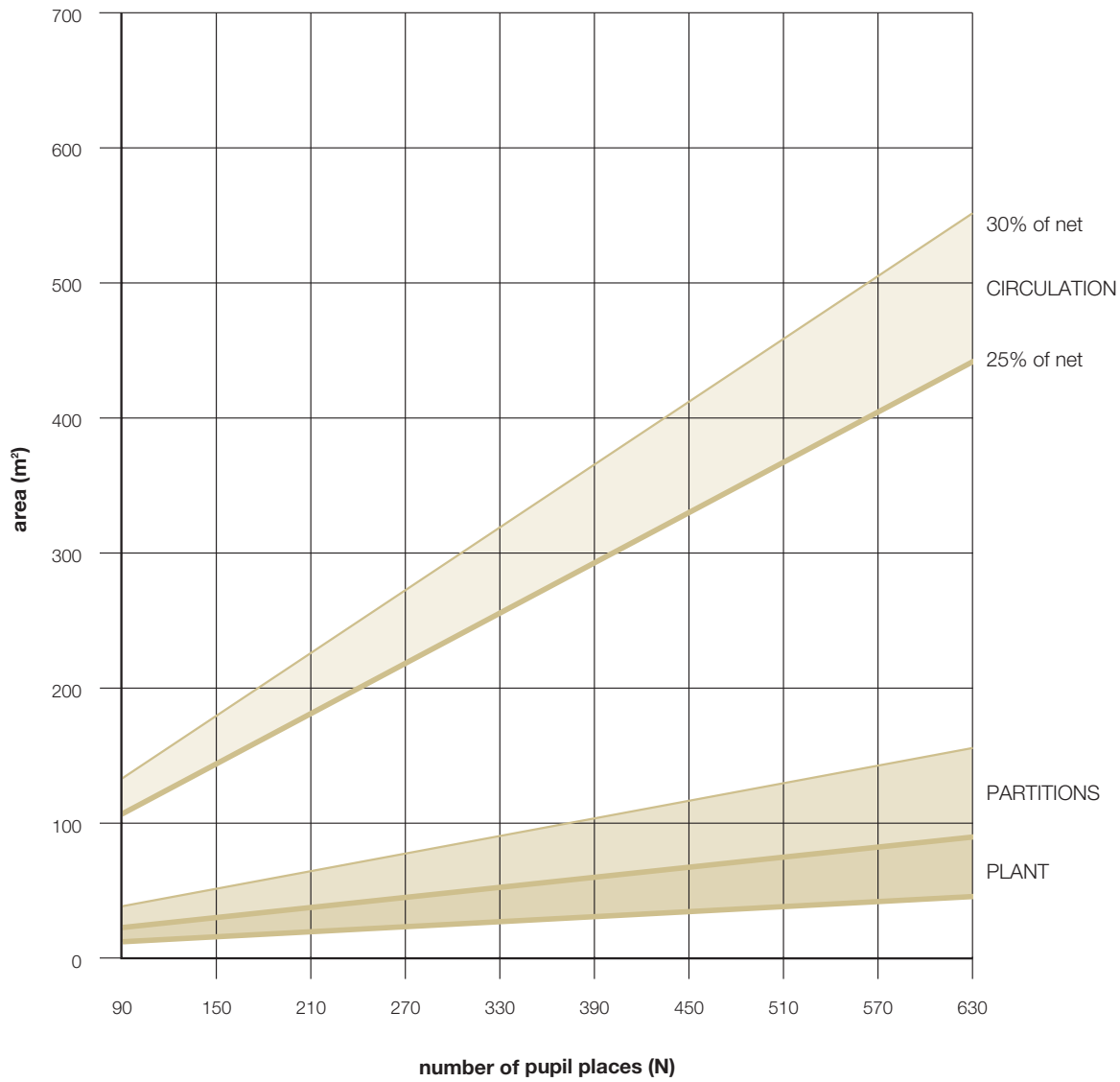

- **accessible toilets** for disabled pupils, staff or visitors¹. Toilets for the disabled may count towards staff provision.

Toilets and personal care should also include:

- a **specialist hygiene** room containing a shower, sluice, toilet, a changing trolley, fixed or mobile hoist and space for assistants. If it is adjacent to the nursery playroom then it could also be used for the general hygiene requirements of the nursery.

Some of the spaces listed above may be required to allow for:

- **adult community** use outside the school day, for instance to provide changing facilities with showers to complement the hall²;
- **changing facilities** with showers for pupils – schools may consider these to be a priority, particularly for older pupils, and may wish to use their ‘float’ to provide specific facilities. Appendix 3 shows a sample schedules of accommodation with changing room provision, both with and without showers³;
- particular **religious requirements**, including orientation and ablutions.

The location and design of toilet and hygiene room facilities should balance the demands of both privacy and adequate supervision. Toilets should have separate cubicles and separate facilities for boys and girls⁴. In washrooms for boys, up to two-thirds of the fittings may be urinals. Lavatories for nursery pupils are usually grouped within easy reach of the teaching/play space as well as the playground and can be unisex. The design of the partitions should allow some privacy for children and space for adults to give assistance. Partitions should, however, allow teachers to supervise children from teaching/playroom spaces if necessary and, as such, should not be full height.

The size, location and design of toilets can have an impact on the potential for bullying. Supervision and inclusion are also concerns. Certain decisions should be made early in the planning process. For example: whether to have one or two central toilet ‘blocks’ or several smaller facilities; and whether to have direct access to the toilets from the classroom and/or the playground. The diagrams in the outer margin look at options where coats and bags storage and toilets are directly located off classrooms.

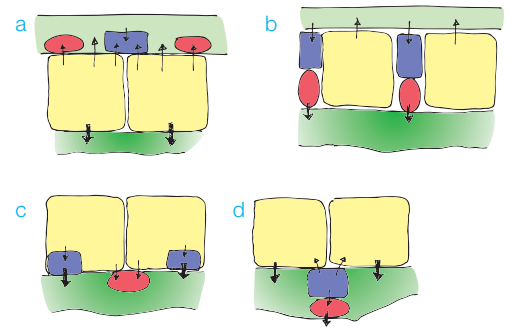

Key: ■ = class base
■ = external circulation
■ = internal circulation
■ = toilet block
■ = coats and bags

a: Each class has its own toilet with a coats and bags lobby shared. Access to both is from the classroom or corridor only which would be necessary as each toilet is single sex. The position of coats and bags storage assumes that children arrive at school via internal doorways.

b: Toilets and coats and bags storage for each classroom are back to back, with access to coats and bags via the corridor only (this assumes pupils arrive at school using internal doorways). External access is possible via coats and bags lobby, this frees up the external classroom wall for a variety of furniture layouts.

c: Access to external areas is via a coats and bags lobby for each classroom and assumes that children arrive at school via external doorways. Shared toilet block is accessible from the classroom only.

d: Access to both toilets and coats and bags is possible during playtime. An additional exit via the classroom is also shown, to ease congestion. Both blocks would, however impede on the playground layout and the amount of usable external wall space.

¹. Refer to Building Regulations, Approved Document M and BS 8300.

². For information on changing facilities for community use see Sport England guidance note ‘Sports Halls: Design’ (ISBN 1-86078-094-6).

³. Changing rooms for primary schools are not generally provided with showers, and as such should be counted within the net area. Changing rooms with showers (usually needed for community use) count as non-net area.

⁴. see Education (School premises) Regulations 1999.

Figure C.10: Kitchen and dining areas

Zone K for the kitchen and N for dining area in the graph recommends a range of area based on the size of the school. The kitchen zone will vary depending on the type of preparation system, as discussed on page 49. The dining area, usually available in the main hall, may be at the lower end of zone N if up to 75% of pupils eat in this area in the equivalent of three sittings, or most of the school eat in four sittings. The upper end would be needed if most of the school eat in the equivalent of three sittings, as is more typical. If more area is available, such as in small schools, there may be the equivalent of two sittings.

The graph also shows the recommended area for toilets and personal care facilities, in zone M. The upper end of the zone may be needed if there is a substantial requirement for hygiene and toilet facilities for pupils with special educational needs.

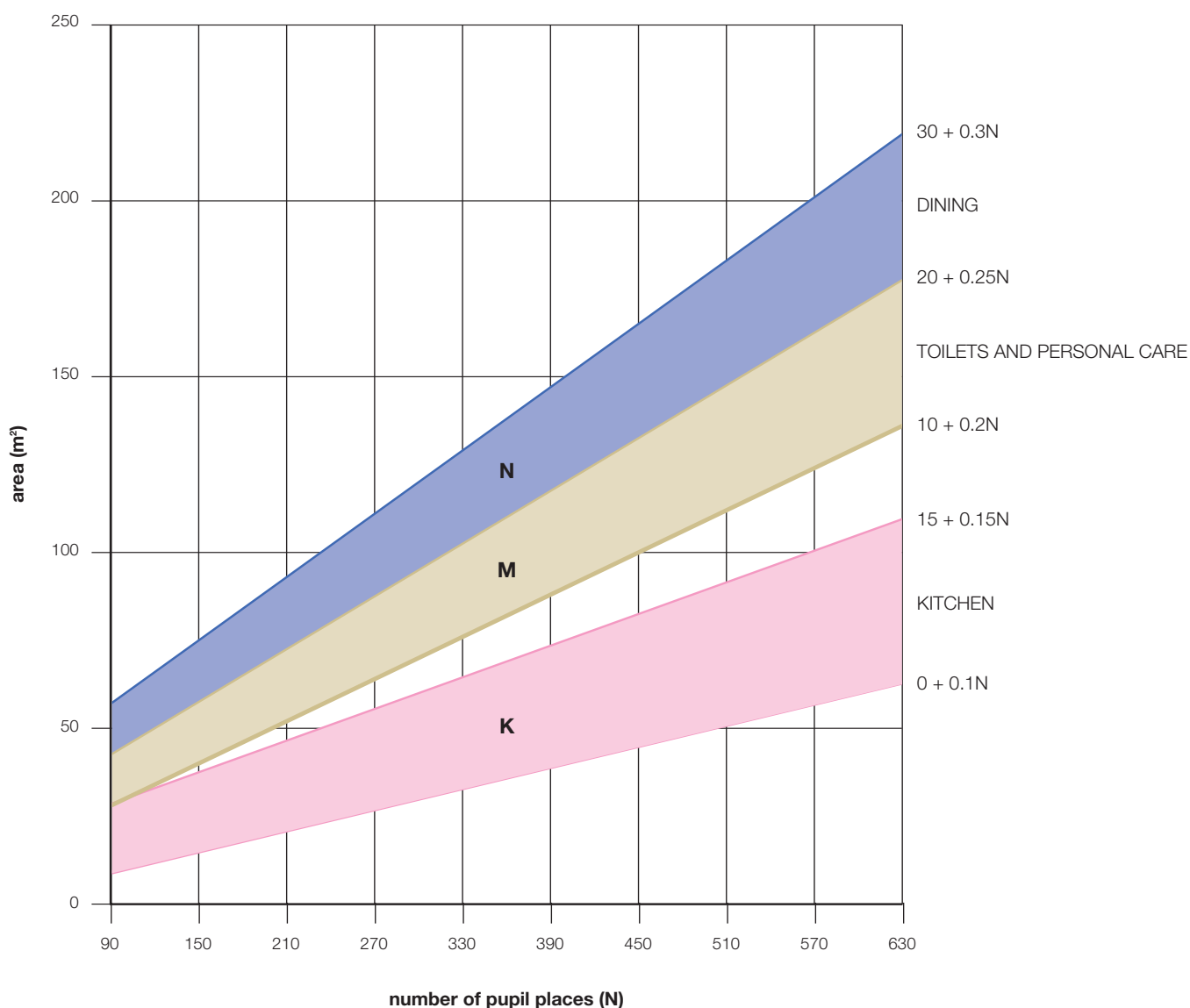

2: Kitchen facilities (zone K)

The kitchen area must¹ include:

- facilities for preparing food and drink, and washing up afterwards².

Where the kitchen is used to prepare hot food for pupils, it should also include:

- adequate facilities and area for safely preparing and cooking food;
- facilities for catering staff, including changing areas, toilets and a chef's office;
- separate facilities for storing cleaning materials in accordance with COSHH³ regulations;
- separate secure storage for dry goods;
- refrigerated and freezer cabinets or rooms;
- adequate circulation for goods in and waste out;

The size of the core preparation area will depend on the equipment needed, which in turn will depend on the type of preparation system to be used, from traditional through cook-chill to pre-prepared food, and also the effective number of sittings. Specialist advice from a kitchen designer should be sought early on in the project to ensure that the space allocated is sufficient and appropriately shaped and located.

The graph in Figure C.10 shows a range of areas for kitchens. The areas given in the lower end of the range would be suitable only for the preparation of drinks and basic food such as sandwiches⁴.

Further space will be required to provide for a servery area⁵, perhaps as a separate space doubling as the dining table and chair store.



Hint: Appendices 1, 2 and 3 assume there is a separate dining furniture store and servery area. If these form the same space, with easy access to the dining room, then they can be used more efficiently

1. Some primary schools have no kitchen facilities for hot meals, while others act as a catering centre providing a number of surrounding schools with meals. The range of possible areas needed therefore varies widely.

2. The Education (School Premises) Regulations 1999 require school buildings to be 'adequate to permit the provision of appropriate ancillary facilities for the preparation or serving of food and drinks and the washing of crockery and other utensils.'

3. If this is part of the kitchen then an area should be identified as part of servery allocation. See HSG 97, A Step by Step guide to COSHH Assessments (revised edition), HSO Books, 2004

4. At the time of writing the DfES are planning to issue design guidance on kitchens and dining rooms. See www.teachernet.gov.uk/schoolbuildings for more details.

5. What is a servery? the area taken up by food cabinets, tray returns, tills and area for catering staff to serve food.

3: Circulation

An area equivalent to at least 20% to 25% of the total net area (including any supplementary net area) will be required to ensure that:

- all rooms except storerooms are accessed from a circulation route¹;
- corridors leading to more than two teaching rooms have a clear width of at least 1.8m (preferably 1.9m in new schools);
- smaller corridors have a clear width of at least 1.2m.

Ideally long corridors should have regular indents or passing places in them, particularly in schools with wheelchair users.

4: Plant

An area equivalent to at least 2% of the total net area will be needed to accommodate boiler rooms and a server room in larger schools. Further area will generally be needed if ventilation plant, chimneys or vertical ducts are included in the design. This allocation includes a server room, which may need to be cooled and should be large enough to access the equipment inside.

5: Internal walls

Internal walls² will occupy an area equivalent to at least 4% of the net area, and up to 7% if the walls are wider to allow for acoustic separation and/or to provide thermal mass. Sliding/folding partition walls must be included in the calculation.

Supplementary areas

The briefing team should assess whether there is a need for any supplementary net area within the project³. It is important to note that a dedicated, additional funding stream needs to be identified for any supplementary net area (unless it already exists in appropriate accommodation), as discussed in relation to extended schools provision on page 19⁴.

Hint: Effective and creative use can be made of circulation area, from spaces for informal gathering and display of work off corridors to atria. However, ensure that any extra space can be effectively used if it is to be heated, lit and maintained.



Hint: When considering the brief for a complete overhaul of a school, ensure the needs of all stakeholders are included, to avoid any current temporary provision having to remain for the want of funding.



1. Circulation area can be the routes within a larger room or atrium, and the remaining area will count towards the usable net area of the school if it is wider than 1.2m. See 'Assessing the Net Capacity of Schools' DfES/0739/2001 REV at www.dfes.gov.uk/netcapacity

2. The area of internal walls is included in the measured internal gross area of the buildings.

3. Non-school and support functions require further area over and above the recommended net area. They are not expected to be included in the float.

4. See 'Designing schools for Extended Services' publication (ISBN 1-84478-739-7) for management models, download from www.teachernet.gov.uk/publications

There are three types of spaces that fall within the category of supplementary area:

- *area to accommodate the enhancement of school facilities*: this will include spaces which have been enlarged beyond the recommended ‘standard’, for instance to allow for spectators or national standards in the sports hall or changing rooms as part of the sports-hall provision;
- *area to accommodate extra support facilities*: this will include separate spaces available to the school for specific uses, such as a sensory support unit for disabled pupils; and
- *non-school provision*: this is separate space on the school site not normally available to the school, for example facilities for adult education or community use during the day.

In an extended school there may be some cases during the school day when both the pupils and the community will use the same space, for example, an ICT-rich area¹.

Although this bulletin does not include recommended standards for the supplementary net area, it is very important to include the desired allowance for supplementary net area in the total net area and the accommodation schedule. This will ensure that the allowance for the related non-net area is sufficient to allow for the circulation, plant and internal walls.

The table below gives examples of some of types of non-school or support facilities or provision that would normally need supplementary area, including a proportional amount of non-net circulation, plant and area of internal walls. It also lists funding sources that could cover this².



1. Careful consideration must therefore be given to the size of furniture. It may be necessary to carefully timetable the use of these spaces, to allow furniture to be re-arranged or (if necessary) brought out from an adjacent store.

2. These are listed under headings that match those used to identify area that is measured but excluded in net capacity assessments.

Examples of supplementary net areas	Likely funding
• Facilities for 0 to 3 year olds and 'wrap-around' care;	Sure Start
• Nursery facilities for 3 to 4 year olds;	Early Years/LA
• Specially resourced provision for pupils with SEN or disabilities;	LA
• Centres for LA Services, such as staff training;	LA
• Extra facilities to allow community use during the school day or not available to the school (such as a club room);	LA leisure or local community groups
• Indoor swimming pool;	LA Leisure or New Opportunity Funds
• Chapel or prayer room (if it is not available to the school for normal teaching);	Voluntary aided governors liability or dioceses
• Health care provision	Primary Care Trust

Figure D.1: Gross site area and net site area defined

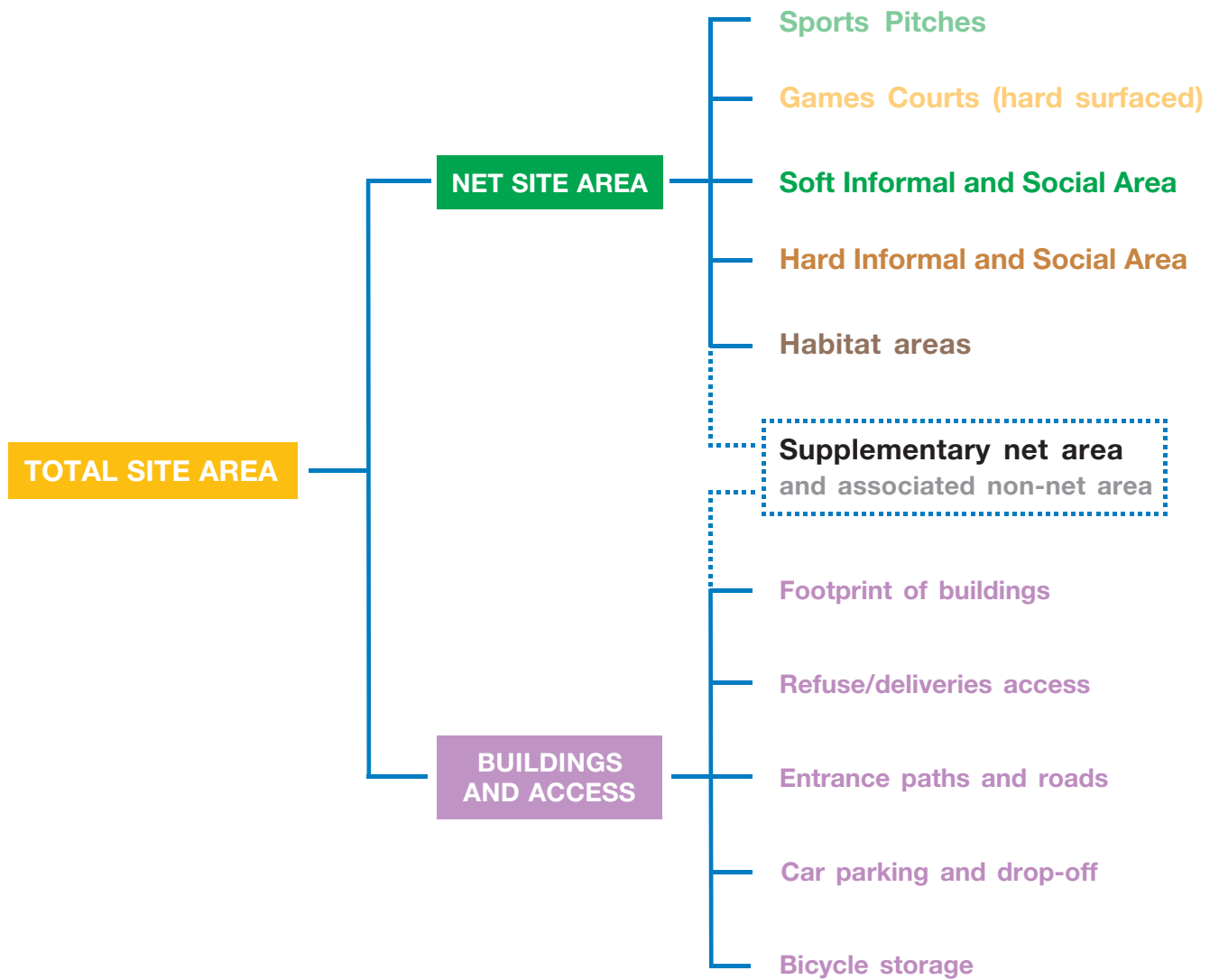

Part D: The Site

This part deals with the site area for any primary school. School grounds are a valuable resource and have a significant effect on the ethos of the school and the quality of education pupils receive¹.

The total, or gross, area of the site can be separated into two categories:

- **net site area**, or playing field area, which can be accurately calculated from the formulae in Appendix 4 plus any agreed supplementary net site area, and
- **buildings and access area**, which will be more variable depending on the configuration of new and existing buildings and site constraints, but will generally increase in proportion to the net site area.

The total of these categories gives the gross (total) area of the site, as described in Figure D.1 on page 52.

The total site area required will depend on the position and layout of the site and the design of the buildings. Generally, the gross site area needed for a new 5 to 11 primary school may vary between 110% and 125% of the net site area (such that the net site area is 80% to 90% of the total)². The net site area for infants' schools is likely to be smaller as there is no requirement for pitches. The gross site area may therefore be as high as 135% of the net site area (i.e. the buildings and access area is a larger proportion of the total site). An inclusive community school need not normally exceed the recommended net site area for the number of pupil places and age range of the school, unless pitches are provided off-site.

Further **supplementary net site area** may be needed if there are specially resourced supplementary non-school or support functions on the school site (for example an external play area for a community nursery). Conversely a need for supplementary net site area (such as a community all-weather sports pitch) may require a proportional increase in buildings and access area.

Defining the total site area is an important step for a new school. Figures D.2 and D.3 on page 54 give the recommended area formulae for gross and net site area. Reviewing the site area against the graph is also useful when considering alterations to an existing school. The range in the graph allows for variation in the shape and contours of the site, and size of the building footprint.



Hint: Site layout: dispersed buildings on the site can be easier for community access, and give identity to age-related bases, such as foundation stage, and may provide better supervision of enclosed outdoor areas. Linked, concentrated buildings can offer internal circulation, more flexible use of the facilities and more long-term adaptability.

1. Building Bulletin 71: The Outdoor Classroom second edition, TSO 1999 (ISBN 0-11-271061-1) and Building Bulletin 85: School Grounds, A Guide to Good Practice, TSO 1997 (ISBN 0-11-270990-7), give advice on the educational design and management of external spaces. A further bulletin on school grounds is due out in late 2006.

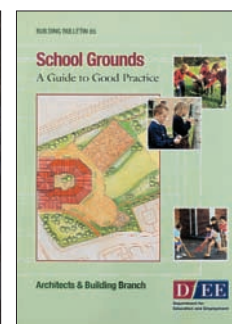
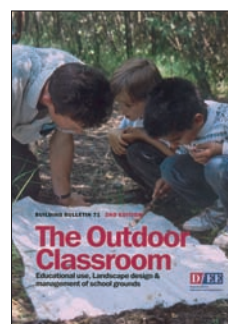

2. This calculation only relates to the total area of the site including playing fields. The proportion of buildings and access area on a confined site, or one where playing fields are elsewhere, will be much higher.

Figures D.2: Site area

Figure D.2 shows recommended standards for total and net site area and for sports pitches, for various sizes of 5 to 11 primary schools. Figure D.3 shows the minimum recommended areas for games courts, informal and social area (soft and hard play) and habitat in any school.

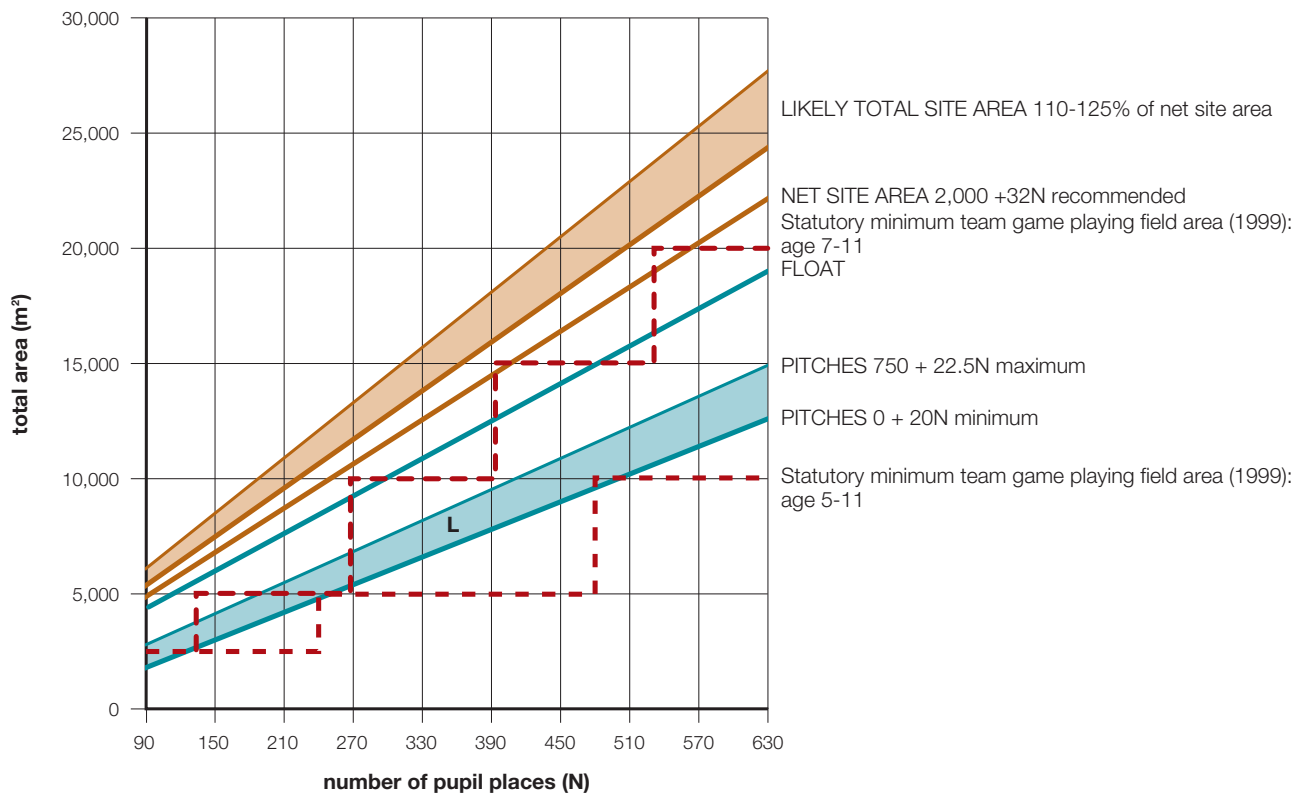
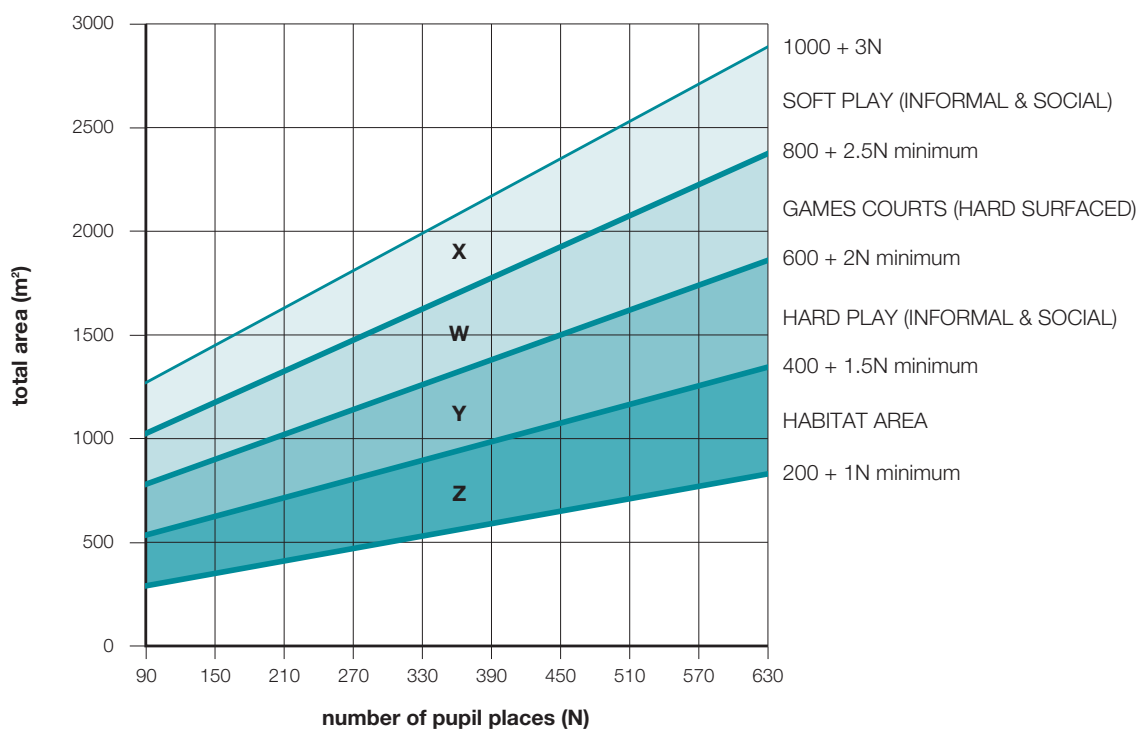

Figure D.3: Remaining four categories of net site area



Net site area

The net site area, known as the 'playing fields area' in some cases¹, is the total of the following five categories of space, plus any supplementary net site area needed for non-school or support functions.

- 1: Sports pitches
(in schools with junior pupils only) (zone L);
- 2: Games courts (hard surfaced) (zone W);
- 3: Soft play (informal and social) (zone X);
- 4: Hard play (informal and social) (zone Y);
- 5: Habitat areas (zone Z).

The bottom of each zone, which can be calculated using the formulae shown in Figures D.2 and D.3 on page 54, represents the minimum recommended area for that category of space.

The total area for each of these categories should ideally be at least the minimum recommended in this bulletin (i.e. the bottom of the zone)². An area greater than the minimum but within the zone will usually be required for each category. The overall recommended net and gross area allows for the area of each category of space to average around the middle of each zone, through the provision of some 'float'³, as with the buildings area.

In confined sites, the sports pitches area may be provided on a nearby site and/or through a single all-weather pitch. Where there are no other outdoor PE facilities on the site, a multi-use games area (see page 57) within zone W should be provided on the site, to allow easy access for outdoor team games. The area of the remaining three categories of space may only be achievable at the zone or area below that recommended for normal sites. Rooftop play areas or 'playdecks' may be another way of increasing the outside area available to pupils.

Nursery classes

The area per place for primary school pupils can be used as a guide for nursery pupils, except in the case of games courts or playing fields where there is no requirement.



1. Section 77(7) of the School Standards and Framework Act 1998, which is designed to protect school playing fields, defines 'playing fields' as 'any land in the open air which is provided for the purposes of physical education or recreation, other than any prescribed description of land'.

2. In split sites, unlike the net area for buildings, the total area for each category should be applied across all sites. So, for instance, the sports pitches may all be provided on one site. Ideally, there should be some informal and social area on each site.

3. What is the float? When you add together the recommended minimum area of each category of space within the total net area, it will be around 5 to 10% less than the recommended standard as identified in Figure D.2. This difference provides the 'float' which can be used to enhance some areas, depending on the design of the site.

Figure D.4: Typical site plan

A site plan of a primary school, with the various categories of net site area and buildings and access area shown.



Key:

- 1 sports – volleyball and tennis
- 2 junior play
- 3 outdoor classroom
- 4 performance space
- 5 rubber play and traversing wall
- 6 infant playground, talk tubes
- 7 visitor and maintenance
- 8 floodlit sports – football and basketball
- 9 landscaped courtyards
- 10 covered drop-off
- 11 external toilets and stores
- 12 staff and nature areas
- 13 car park
- 14 sensory planting
- 15 pergola/quiet area
- 16 changing rooms

(New buildings shown hatched)

Outdoor PE facilities

The first two categories of net site area (zones L and W) add up to the area used for Physical Education (PE)¹ and will generally match the statutory requirement² for ‘team game playing field area’ for pupils aged eight and over.

Careful attention should be given to the layout of pitches, courts and practice areas³. Their location, size and shape should be based on a number of considerations including the statutory requirements, safety considerations, gradient, relationships between winter-games pitches and summer athletics and cricket provision (as appropriate), orientation of pitches and accessibility⁴.

1: Sports pitches (zone L)

The total area of sports pitches must include playing field area laid out to suit team games for pupils aged eight and over, including:

- winter pitches for the school’s preferred team games, such as football;
- overlapping summer pitches, such as a 100-metre athletics track and facilities for field events.

All-weather pitches, including synthetic turf pitches⁵ or polymeric surfaces⁶, allow more intensive use than grass and, particularly with floodlighting, can also offer a popular year-round community resource.

The area of all-weather pitches can be counted twice for the purposes of these guidelines and regulations, as they can be used for significantly more than the seven hours a week required of team game playing fields.

2: Games courts (zone W)

In new schools, the total area of hard-surfaced games courts should include:

- a multi-use games area⁷ with a netball court overlaid, with critical dimensions of 22m x 33m plus margins.

Laying out a variety of courts within a single multi-use games area maximises space, makes supervision easier and extends the range of games.

In existing schools, a similar amount of hard-surfaced area should be laid out for games⁸.



1. Refer to ‘Inspirational design for P.E. and Sports Spaces’ Schools for the Future series, 2005 (ISBN 0-00000-000-0) Stationery Office.

2. The Education (School Premises) Regulations 1999 define ‘team game playing fields’ as ‘playing fields which, having regard to their configuration, are suitable for the playing of team games and which are laid out for that purpose’.

3. Refer to Sport England ‘Handbook of Sports and Recreational Building Design Volume 1: Outdoor Sports’.

4. Refer to Building Bulletin 91: Access for Disabled People to School Buildings, TSO 1999 (ISBN 0-11-271062-X), Building Bulletin 94: Inclusive School Design, TSO 2001 (ISBN 0-11-271109-X) and Sport England Guidance Note Access for Disabled People (ISBN 1-86078-149-7).

5. See Sport England Guidance Note no. 596: ‘Synthetic Turf Pitches’

6. Such as shredded rubber bonded with bitumen, latex or polyurethane, on a base of concrete laid to fall. See Sport England Guidance Notes and BS7044 Part 4: ‘Artificial Sports Surfaces – Specification for Surfaces for Multi-Sport Use’.

7. See Sport England Guidance Note 374: ‘Multi-Use Games Areas’.

8. This area will count towards the current Education (School Premises) Regulations 1999 requirement for team game playing fields only if it is used for team games.

Informal and social areas

A variety of informal and social areas should be created to suit the learning development and cultural needs of pupils during breaks and before and after school, and for a range of formal curriculum needs.

3: Soft play (zone X)

The 'soft' areas should be conveniently situated, safe and provide some shade. With some imaginative landscaping and planting, the total area could include:

- grassed space to sit and socialise;
- sloping or tiered grass areas to form a natural amphitheatre with provision for spectators.

4: Hard play (zone Y)

To complement the soft informal and social areas, there should be hard surfaced playgrounds and to encourage healthy, active, creative outdoor play.

Site furniture, such as seating can accommodate larger outdoor study groups and in smaller, more intimate areas, is important for both social and learning activities. 'Furniture' can be created through the introduction of natural materials which blend into the landscaping¹. These areas should provide scope for pupils to engage in outdoor art, theatre, dance and design activities using a range of hard surfaces and structures.

The total area should include:

- hard surfaced, sheltered space to sit and socialise;
- large hard surfaced areas for more active play.

5: Habitat areas (zone Z)

Habitat areas can include a range of outdoor classroom spaces and designs and are a valuable resource for teaching and learning across the whole curriculum. They can help children's emotional, social and cultural development². They are also important for involving pupils in the life and management of the school. The total habitat area should include grounds developed for a wide range of supervised activities, including meadowland, wildlife habitats (such as ponds), gardens and outdoor science areas to support the curriculum and improve play and recreational spaces.

Increasingly, such spaces are being given a central and



© Learning Through Landscapes



© Learning Through Landscapes



1. Details and case studies are available from Learning through Landscapes at www.ltl.org.uk which includes a range of advisory services on the use design and management of school grounds.

2. A DfES publication 'Designing School Grounds' is to be published in late 2006.

accessible location. Landscape design has a great potential for promoting a sense of ownership of space by pupils and staff, thereby encouraging people to take greater care of their surroundings. However, some wildlife areas should normally be undisturbed, so are best positioned away from busy social areas. Such areas usually need to be fenced off, both to protect the habitat and for the safety of pupils.

Non-net area

The non-net site area or buildings and access will vary depending on the configuration of the site and buildings. It will include:

- the 'footprint' of all buildings;
- delivery access;
- refuse areas (secure or distant from the buildings);

And will usually include:

- bicycle storage;
- entrance paths, roads and related landscaping not normally available to pupils;
- car parking (usually equivalent to one parking bay per full-time equivalent teaching staff, plus appropriate visitors' and disabled facilities).

And may include:

- coach or bus drop-off provision.

It is most important to consider means of separating children's pedestrian access from vehicular circulation, delivery areas and parking and for providing adequate, visible secure bicycle storage for older pupils.

Supplementary site area

As discussed on page 50, any school may have supplementary areas for non-school or support functions, which may need to be funded through other joined-up funding streams. For instance, play space for a crèche, extra car parking for community use, or enhancements to sports provision also used by the community.



© Learning Through Landscapes



Appendices

The following pages include various example schedules of accommodation and the key formulae for primary schools. The schedules are intended to demonstrate just some of the ways that space can be allocated within the recommended zones of net and non-net area. Many others are possible.

Appendix 1 shows full schedules for two sizes of infant school and three sizes of junior school.

Appendix 2 shows full schedules for five typical sizes of 5 to 11 primary school, any of which (like the infant schools in appendix 1) could have an additional nursery through an extra net area including a 57m² playroom, 12m² small group room, 7m² store and 5m² of staff accommodation, plus 34m² of non-net area.

In both these appendices, the hall is used for serving of hot meals, in either two or three sittings, depending on whether half or a third of the pupils in the school can be accommodated at one sitting. The size of the chair and table store then relates to the number of places needed in each sitting.

Appendix 3 shows variations of the schedule for the 420 place 5 to 11 primary shown in appendix 2. Text in red indicates the variations. The net area could vary but totals 1552m² in each example to emphasize the differences possible:

- in the first version, the options of more specialist practical spaces (either two different spaces for half a class, for instance for food and science and for art and design/technology, or one space for a whole class);
- in the second version, an 18m x 10m 'one-court' sports hall;
- in the third, a dining hall rather than a small hall; and
- in the last, fully inclusive classrooms accommodating all activities except those in the halls.

The non-net area ranges from 140% to 145% of net, to show the differences made by variations in the size of the kitchen, circulation (for instance for internal ramps in schools on sloping sites), plant (for instance to suit wood-fired boilers) and partitions (which may be wider for acoustic separation or to provide thermal mass).

Appendix 1:

Example schedules for various sizes of infant and junior schools

pupil places			90 pupils		180 pupils		120 pupils		240 pupils		360 pupils	
number of classes			3 classes		6 classes		4 classes		8 classes		12 classes	
Forms of Entry (FE) and type			1 FE infants		2 FE infants		1 FE junior		2 FE junior		3 FE junior	
	maximum group size	average area (m ²)	no. of rooms	total area (m ²)	no. of rooms	total area (m ²)	no. of rooms	total area (m ²)	no. of rooms	total area (m ²)	no. of rooms	total area (m ²)
basic teaching												
reception class	30	66	1	66	2	132						
infant classbase	30	60	2	120	4	240						
junior classbase	30	60					4	240	8	480	12	720
<i>specialist practical</i>												
food/science/D&T	8	24	1	24	1	24	1	24				
food/science/D&T	8	38							1	38	1	38
ICT suite	(no. of computers)		(15*)	38	(15)	38	(15*)	38	(16)	38	(24)	56
halls												
main hall (used for dining)	30		1	125	1	150	1	140	1	180	1	180
small hall	30	80										
studio	30	50									1	50
learning resource areas												
Library resource centre	15 to 30		1	18	1	24	1	21	1	29	1	37
small group room (SENco)	5 to 8	12	1	12	1	12	1	12	1	12	1	12
small group rooms	5 to 8	9			1	9	1	9	1	9	2	18
TOTAL TEACHING AREA				403	629	484	786	1111				
staff and admin.												
head's office/meeting room			1	10	1	12	1	10	1	12	1	14
senior management offices		8							1	8	1	8
staff room			1	18	1	28	1	20	1	35	1	50
general office			1	8	1	10	1	8	1	10	1	12
sick bay (adjacent)		3	1	3	1	3	1	3	1	3	1	3
entrance/reception			1	2	1	3	1	3	1	4	1	5
copier/reprographics				2		5		2		5		7
SENco/MI/group room		12	1	12	1	12	1	12	1	12	1	12
interview/social services		8			1	8			1	8	1	8
storage												
class storage (reception)		3	1	3	2	6						
class storage (infant and junior)		1.5	2	3	4	6	4	6	8	12	12	18
specialist stores		6 or 8	2	12	2	16	2	16	3	18	3	24
PE store (adjacent to hall)		12	1	12	1	12	1	12	1	12	1	12
PE store (external)		4	1	4	1	4	1	4	1	4	1	4
<i>non-teaching storage</i>												
central stock		8	1	6	1	8	1	8	1	8	1	8
cloakrooms/lunch box storage		3		9		18		12		24		36
dining chair/table store	(no. of sittings)		(2)	7	(2)	12	(2)	8	(2)	12	(3)	12
staging/appliance store			1	4	1	4	1	4	1	8	1	8
community store		4	1	4	1	4	1	4	1	4	1	4
caretakers/maintenance store			1	4	1	5	1	4	1	5	1	6
cleaner's store		1.5	2	3	2	3	2	3	2	3	3	4.5
TOTAL NET AREA				529	808	623	993	1367				
recommended net area				529	808	622	994	1366				
non-net area												
kitchen (full-service)			1	28	1	41	1	32	1	50	1	68
servery				6		6		6		8		8
toilets (and personal care)												
reception toilets			2	8	3	12						
other pupil toilets				10		20		20		40		60
accessible toilets/hygiene facilities				10		12		10		12		14
staff toilets				3.5		7		7		10.5		14
circulation												
plant (incl. server)		net x 22.5%		119		182		140		223		307
partitions		net x 3%		16		24		19		30		41
		net x 5%		26		40		31		50		68
TOTAL GROSS AREA				756	1152	888	1417	1947				
recommended gross area (gross at 142.5% of net)				754	1151	886	1416	1947				

* see question 19, page 6

Appendix 2:

Example schedules for various sizes of 5 to 11 (JMI) schools

pupil places			105 pupils		210 pupils		315 pupils		420 pupils		630 pupils	
number of classes			3.5 classes		7 classes		10.5 classes		14 classes		21 classes	
Forms of Entry (FE) and type			0.5 FE JMI		1 FE JMI		1.5 FE JMI		2 FE JMI		3 FE JMI	
	maximum group size	average area (m ²)	no. of rooms	total area (m ²)	no. of rooms	total area (m ²)	no. of rooms	total area (m ²)	no. of rooms	total area (m ²)	no. of rooms	total area (m ²)
basic teaching												
reception class	30	66	0.5	33	1	66	1.5	99	2	132	3	198
infant classbase	30	60	1	60	2	120	3	180	4	240	6	360
junior classbase	30	60	2	120	4	240	6	360	8	480	12	720
<i>specialist practical</i>												
food/science/D&T	8	24	1	24	1	24	1	24				
food/science/D&T	15	38							1	38	1	38
ICT suite	(no. of computers)		(15*)	38	(15)	38	(23)	54	(30)	68	(30*)	68
halls												
main hall (used for dining)	30		1	140	1	180	1	150	1	150	1	200
small hall	30	80							1	80	1	80
studio	30	50						1	50		1	50
learning resource areas												
Library resource centre	15 to 30		1	19	1	26	1	33	1	40	1	54
small group room (SENco)	6	12	1	12	1	12	1	12	1	12	1	12
small group rooms	6	9			1	9	2	18	3	27	5	45
TOTAL TEACHING AREA				446		715		980		1267		1825
staff and admin.												
head's office/meeting room			1	10	1	12	1	14	1	16	1	20
senior management offices		8							1	8	1	8
staff room			1	19	1	32	1	45	1	58	1	84
general office			1	8	1	10	1	12	1	14	1	18
sick bay (adjacent)		3	1	3	1	3	1	3	1	3	1	3
entrance/reception			1	2	1	3	1	4	1	5	1	7
copier/reprographics				2		4		6		8		12
SEN therapy/MI room		12	1	12	1	12	1	12	1	12	1	12
interview/ social services		8	1	8	1	8	1	8	1	8	1	8
storage												
class storage (reception)		3	1	3	1	3	1	3	2	6	3	9
class storage (infant and junior)		1.5	3	4.5	6	9	9	13.5	12	18	18	27
specialist stores		6 or 8	2	12	3	18	4	24	3	24	4	32
PE store (adjacent to hall)		12	1	12	1	12	1	12	1	12	2	16
PE store (external)		4	1	4	1	4	1	4	1	4	1	4
<i>non-teaching storage</i>												
central stock		8	1	6	1	8	1	8	1	8	1	8
cloakrooms/lunch box storage		3		10.5		21		31.5		42		63
dining chair/table store	(no. of sittings)		(2)	7	(2)	12	(2)	16	(3)	16	(3)	20
staging/appliance store			1	4	1	4	1	8	1	8	1	8
community store		4	1	4	1	4	1	4	1	4	1	4
caretakers/maintenance store			1	4	1	5	1	6	1	7	1	9
cleaner's store		1.5	2	3	2	3	3	4.5	3	4.5	4	6
TOTAL NET AREA				576		902		1227		1553		2203
recommended net area				575.5		901		1226.5		1552		2203
non-net area												
kitchen (full-service)			1	29	1	45	1	61	1	77	1	109
servery				6		6		8		8		10
toilets (and personal care)												
reception toilets			1	4	2	8	3	12	3	12	5	20
other pupil toilets				15		30		45		60		90
accessible toilets/hygiene facilities				10		12		14		16		20
staff toilets				3.5		7		10.5		14		21
circulation		net x 22.5%		130		203		276		349		496
plant (incl. server)		net x 3%		17		27		37		47		67
partitions		net x 5%		29		45		61		78		110
TOTAL GROSS AREA				820		1285		1749		2212		3139
recommended gross area (gross at 142.5% of net)				820		1284		1748		2212		3139

* see question 19, page 6

Appendix 3:

Example schedules – variations for a 420 place 5 to 11 school

Variations from 420 place schedule in Appendix 2 shown in red		specialist practical minimal non-net areas			community hall & parents' room sloping site			dining hall and small ICT room access and hygiene facilities			large classrooms toilets and renewable energy		
	maximum group size	no. of rooms	average area (m ²)	total area (m ²)	no. of rooms	average area (m ²)	total area (m ²)	no. of rooms	average area (m ²)	total area (m ²)	no. of rooms	average area (m ²)	total area (m ²)
basic teaching													
reception class	30	2	63	126	2	63	126	2	66	132	2	70	140
infant classbase	30	4	57	228	4	57	228	4	61	244	4	63	252
junior classbase	30	8	57	456	8	57	456	8	61	488	8	63	504
<i>specialist practical</i>													
food bay	0							1	4	4	1	4	4
food/science/D&T	15	2	38	76	1	24	24	1	38	38			
ICT suite	(no. of computers)	(30)		72	(30)		68	(15)		38	(0)		all ICT in classrooms
TOTAL (882to 954 recommended)				958			902			944			900
halls													
main hall	30	1		150	1		180	1		150	1		180
small hall or studio	30	1		80	1		80				1		50
dining hall								1		108			
TOTAL (226 to 262 recommended)				230			260			258			230
learning resource areas													
Library resource centre	15 to 30	1		40	1		40	1		40	1		40
small group room (SENco)	6	1		12	1		12	1		12	1		12
small group rooms	6	3	9	27	3	9	27	3	9	27	4	9	36
TOTAL (78 to 114 recommended)		15		79	15		79	15		79			88
TOTAL TEACHING AREA				1267			1241			1281			1218
staff and admin.													
head's office/meeting room		1		16	1		8	1		16	1		16
senior management offices		1		8	1		8	1		8	1		8
staff room(s)		2		60	1		58	1		55	1		58
general office & sick bay		1		14	1		14	1		14	1		14
sick bay (adjacent)		1		3	1		3	1		3	1		3
entrance/reception		1		5	1		5	1		5	1		5
copier/reprographics				8			8			8			8
SEN therapy/MI room		1		12	1		12	1		12	1		12
interview/social services		1		8	0		0	0		0	1		8
meeting/multi-agency							16						
parents'/community room					1		24				1		24
TOTAL (114 to 150 recommended)				134			156			121			156
storage													
class storage (as appendix 2)		14		24	14		24	14		24	14		24
specialist stores		3	7	21	3	7	21	3	8	24	4	7	28
PE store (adjacent to hall)		1		12	1		16	1		12	1		12
PE store (external)		1		4	1		4	1		4	1		4
changing (without showers)											1		20
<i>non-teaching storage</i>													
central stock		1		8	1		8	1		8	1		8
cloakrooms/ lunch box storage		14	3	42	14	3	42	14	3	42	14	3	42
dining chair/table store		1		16	1		16	1		12	1		16
staging/ appliance store		1		8	1		8	1		8	1		8
community store		1		4	1		4	1		4	1		4
caretakers /maintenance store		1		7	1		7	1		7	1		7
cleaner's store		3	1.7	5	3	1.7	5	3	1.7	5	3	1.7	5
TOTAL (150 to 186 recommended)				151			155			150			178
TOTAL NET AREA				1552			1552			1552			1552
non-net area													
kitchen			reheat/fast food	42		snack/cold food	53		cook/chill	65		full service	78
servery										8			12
toilets (and personal care)	(4% to 7% of net)	5.8%			5.8%			6.1%			6.7%		
reception toilets		3	4	12	3	4	12	3	4	12	3	4	14
other pupil toilets		6		60	6		60	6		60	6		68
accessible/visitors' toilets		1	4	4	1	4	4	2	4	8	2	4	8
hygiene room with showers		1		12	1		12	2		24	1		16
staff toilets				14			14			14			14
changing with showers							24						
TOTAL (94 to 125 recommended)				102			126			118			120
circulation	(20% to 25% of net)	22.5%		349	25.0%		388	22.5%		349	20.4%		317
plant (incl. server)	(2% to 4% of net)	3.2%		50	3.0%		47	3.0%		47	4.0%		62
partitions	(4% to 7% of net)	5.0%		78	4.0%		62	5.0%		78	7.0%		109
TOTAL GROSS AREA				140.0%			2173	143.6%		2228	142.8%		2217
													145.0%
													2250

Appendix 4: Key Formulae

Key Formulae for Typical Primary Schools

N = number of pupil places (or full-time equivalent where applicable)

Minimum Building Areas	all primary schools	5 - 12 first and middle schools	8 - 12 middle schools
basic teaching	2.1N	50 + 2.2N	50 + 2.3N
halls	100 + 0.3N	250 + 0.3N	250 + 0.3N
learning resources	15 + 0.15N	50 + 0.16N	50 + 0.17N
staff & administration	30 + 0.2N	75 + 0.21N	75 + 0.22N
storage	45 + 0.25N	100 + 0.26N	100 + 0.27N
dining & social	-	-	25 + 0.05N
'float'	60 + 0.1N	175 + 0.12N	150 + 0.14N
TOTAL NET BUILDING AREA	250 + 3.1N	700 + 3.25N	700 + 3.45N
LIKELY GROSS BUILDING AREA	340 + 4.5N	1000 + 4.5N	1000 + 5N

Minimum Site Areas	infant schools (except confined sites)	5 - 11 primary schools (except confined sites)	primary schools on confined sites
pitches	-	20N	provided 'off-site'
soft play (informal & social)	800 + 2.5N	800 + 2.5N	600 + 2N
games courts (hard surfaced)	600 + 2N	600 + 2N	1000 (MUGA)
hard play (informal & social)	400 + 1.5N	400 + 1.5N	200 + 1N
habitat	200 + 1N	200 + 1N	0.5N
'float'	5N	5N	remainder of site
TOTAL NET SITE AREA	2000 + 12N	2000 + 32N	1800 + 4N minimum
LIKELY SITE AREA: from	2300 + 14N	2200 + 36N	2500 + 5N
to	2700 + 16N	2500 + 40N	3000 + 6N

The formulae above can be used to calculate the minimum area recommended for any of the schools defined in the headings, provided there are the same number of pupil places in each year. Note that the headings for site areas are different to those of building areas. Gross area figures are approximate to allow an easy 'rule of thumb'. The table below should be used to calculate areas for schools with nursery classes and the site areas for first and middle and middle schools.

Key Formulae for Any Primary School (except special)

Minimum Building Areas	Area for each school:			Area for each pupil place in:			
	For any primary school	For any middle school	For any 'first and middle' school	nursery	reception and KS1	KS2	KS3
	Likely gross area of buildings = net area x 1.4 to 1.45						
basic teaching	-	50	50	2.1	2.1	2.1	2.9
halls	100	250	250	-	0.3	0.3	0.3
learning resources	15	50	50	0.45	0.15	0.15	0.25
staff & administration	30	75	75	0.2	0.2	0.2	0.28
storage	45	100	100	0.25	0.25	0.25	0.33
dining & social	-	25	25	-	-	-	0.2
'float'	60	150	150	0.1	0.1	0.1	0.24
TOTAL NET BUILDING AREA	250	700	700	3.1	3.1	3.1	4.5
	Likely total site area = net site area x 1.1 to 1.35						
pitches	-	10000	7500	-	-	35	35
soft play (informal & social)	800	800	800	2.5	2.5	2.5	2.5
games courts (hard surfaced)	600	600	600	-	2	2	2
hard play (informal & social)	400	400	400	1.5	1.5	1.5	1.5
habitat	200	200	200	1	1	1	1
'float'	-	1000	500	5	5	5	5
TOTAL NET SITE AREA	2000	13000	10000	10	12	47	47

The formulae above can be used to calculate the minimum area recommended for any primary, first and middle, or middle school, including those with different numbers of pupil places in year groups, and those with nursery classes.